

DIN-Gauge
 Style 21: DF14401, DF14402, DF14403, DF14404
 Style 98 Hommage: DF14405, DF14406

Thank you very much for purchasing our product.
 This product is an additional product for providing information to automobile users about engine conditions and other important factors. Before installing and using the product, please read this manual and the warranty card thoroughly. All sections are for customers and installation personnels. After installation, please keep this manual and the warranty card for future reference. In the event that this product (or the vehicle in which it is installed) is lent to or transferred to another person, please be sure this operation manual and warranty card accompany the product.

Defi will not be held responsible for accidents or damages related to installation of this product.

When installing and operating this product, be sure to read the cautionary items in the operation manual for the vehicle in which this product will be installed in addition to the manual of this product. Please obtain a full understanding of the cautionary items and use the product accordingly. Before using the product, please confirm all the components are included in the package.

Safety Warning [Please read carefully.]

In this manual, the degree of hazard arising from actions such as improper operation is separated into the 3 levels "Danger," "Warning," and "Caution." In addition, instructions that must be followed for safe and proper use of this product as well as practices that must be maintained are marked with a "Confirmation" heading. Please read and become familiar with these sections.

	Danger	Indicates the imminent dangerous situation of death or serious injury if the product is mishandled.
	Warning	Indicates the possibility of death or serious injury if the product is mishandled.
	Caution	Indicates a conceivable source of personal injury or damage to equipment if the product is improperly operated.
	Confirmation	Indicates an instruction that must be performed or practice that must be maintained.

Properties for safety warning

	Indicates attention needs to be paid. (Including warnings)
	Indicates restricted actions. (PROHIBITED actions)
	Indicates actions that need to be carried out. (MUST actions)

Before handling (for installation personnel)

- ⚠ Danger**
- Ensure that the vehicle will remain stationary and turn off the engine before installing this product. Failure to do so could result in a fire, and could make the vehicle move during installation.
 - Remove the key from the ignition and disconnect the negative (-) battery terminal prior to installation of this product. Failure to do so could result in a fire caused by an electrical short circuit.
 - Take care not to install this product in a way that interferes with safety equipment such as seat belts and air bag systems or vehicle operation equipment such as engine controls, steering wheel or brake systems. Interference with normal operation of the vehicle can result in an accident or fire.
 - Solder or use a solderless connector for wiring connections and make sure connections are insulated. In areas where there could be tension or sudden impacts on the wiring, safeguard the wiring with corrugated tubing or other shock absorbent material. Accidental shorts can cause fires.
 - When wiring power supply wire, to avoid the risk of electrical shock or fire, be sure to confirm that there is no disconnection or breakage of wire. Poor connection can result in short-circuit, electrical shock, fire, or other hazards.
 - The ignition-switched +12V(IGN) line must be connected to the vehicle's ignition-switched wire with a fuse of 30A or less. High-capacity fuse(more than 30A) will not blowout even with an abnormal current flow and may cause fire.
 - Discontinue use of this product if a blowout of the fuse has occurred. Continued use while the condition exists could result in an accident, fire, or damage to the vehicle.
 - Use the fuse of regulated capacity when the fuse of the power source wire is changed. Using a fuse that exceeds regulated capacity may cause fire.
 - Do not install the product at the wet places. It may result in a fire caused by an electrical short circuit.
 - Discontinue use of this product if the product doesn't operate or operates improperly. Continued use while the condition exists could result in an accident or fire.

- ⚠ Warning**
- Carefully consider the installation location and driver's operation of the product before installation. Do not install the product where it interrupts driving and the safety devices of vehicle such as the airbag system. Be sure not to install the unit where it could fall. Improper installation or operation could cause the product to fall and damage the vehicle or cause serious danger by impeding driving.
 - Do not disassemble or modify this product. Such actions will not only void the warranty but also damage or destroy the product.
 - Do not perform installation of this product immediately after the engine has been switched off. The engine and exhaust system are extremely hot at this time and can cause burns if touched.
 - Ensure that the wiring of this product does not have an adverse impact on the other wiring of the vehicle. Any controlling devices or other electronic components of the vehicle could be damaged.
 - Do not cut more than one wire at the same time when cutting wires. Cutting several wires together may destroy your ECU, ignition system and other engine management devices.
 - Please keep children and infants away from the installation area. Children may swallow small parts or be injured in other ways.
 - Do not install this product in the area where safety equipment such as airbags are mounted. This may cause more injuries in the event of an accident.

- ⚠ Caution**
- This product is designed for use on 12V vehicles. Do not install this product on vehicles with 24V systems.
 - Insulate any unused wires. If any wires or connectors loosen during installation, please make sure they are correctly reattached.
 - Do not drop any of the components of this product. It may result in damage to the product.
 - Do not apply excessive force on switches/terminals. It may result in damage to the product.
 - Do not use wires other than the provided wires.
 - Do not attach wires on the body of the vehicle or engine parts as this may result in damage to the product.
 - Install wires away from ignition and also radio signal frequency interference as this could cause the gauges to malfunction.
 - Do not place wires near the engine, exhaust pipe or turbine. It may result in damage or fusion of wires.
 - Make sure the waterproof processing is done when diverging wires in the engine compartment.
 - Wear gloves to avoid burns when soldering and cuts when installing wires, sharp edges of parts.
 - Use a dried soft cloth for cleanup. Do not use cleaners except for the neutral detergent. It may damage the product.
 - When installing the sensor, do not bend the wire near the sensor body.
 - Install sensors away from hot or wet places to avoid damage.
 - Do not pull the wires out of connectors forcefully. The connectors may be broken and the wires may be cut. When pulling out the wires, press the lock firmly and unclip the locks of connectors.

- Confirmation**
- Be sure to follow all instructions in this manual to ensure safe installation and operation of the product.
 - When the negative (-) battery terminal is disconnected, equipment such as clocks and audio components having internal memory may lose their memory data. Follow the operation manual of each component to reset data after installation of this product.
 - After installation is complete, return this operation manual, warranty card, and the package to the customer along with the warranty.
 - The gauge pointer may not be in the proper position when you purchase the product. Normal function will resume when power is connected.
 - Please confirm with the maintenance book on the car that the manufacturer issued when installing and detaching genuine parts.
 - Before tapping wires, check the voltage of the existing wire. After tapping the wire, check the voltage of the tapped wire again to confirm whether you have tapped into the proper place.
 - If car navigation system or car television is installed in vehicle, gauges and wires of this product need to be kept as far away as possible from the wiring and installing positions of car navigation system or car television. Failure to do so may result in interference of television display.
 - On no event will Nippon Seiki Co., Ltd. be liable to you for any damages or losses of genuine parts for your vehicle while installing.

About Installation and Operation(for customer and installation personnel)

- ⚠ Warning**
- Please have this product installed by the retail store or dealer where it was purchased. Installation by the customer will void the warranty.
 - Do not disassemble or modify this product. Such actions will not only void the warranty but also damage or destroy the product.
 - In order to ensure safe driving, check the information on the gauge only for short periods of time. Looking at the display for long periods of time could distract adequate attention from the road and result in an accident.
 - Discontinue use of this product if the gauge doesn't operate, water gets into the unit, or smoke or a strange odor comes from the unit. If such a condition occurs, contact the sales outlet or installation personnel as soon as possible. Continued use while the condition exists could result in an accident or fire.
 - Do not operate during driving.
 - Please keep children and infants away from the installation area. Children may swallow parts or be injured in other ways.

- ⚠ Caution**
- On no event will Nippon Seiki Co., Ltd. be liable to you for any damages arising out of the use or inability to use the product, even if Nippon Seiki Co., Ltd. has been advised of the possibility of such damage.
 - Do not pull the wires out of connectors forcefully. The connectors may be broken and the wires may be cut. When pulling out the wires, press the lock firmly and unclip the locks of connectors.

- Confirmation**
- This product cannot be linked to the Defi-Link System and The Defi-Link ADVANCE System.
 - The information displayed on this product are for reference purposes only. Please drive according to the indication of vehicle's originally equipped instruments.
 - This product uses high luminance LEDs. When several gauges are lined up, there might be color difference in the LED production tolerance, but it is not malfunction.
 - In the case of idling stop vehicles, the power of the product is turned off and restarted in some cases by a drop in battery voltage when the engine is restarted while idling stop function is active. It is not malfunction.
 - Please check the installed product regularly. Durability might deteriorate according to use conditions, etc.
 - Dispose of the product according to the local recycling regulations.

Lineup (for customer)

Part Number	Style Name	Dial Color	Color of Characters	Illumination Color	Color of Pointer
DF14401	Style 21	Black	White	White	White
DF14402	Style 21	Black	Amber Red	Amber Red	White
DF14403	Style 21	Black	White	White	Amber Red
DF14404	Style 21	Black	Amber red	Amber red	Amber Red
DF14405	Style 98 Hommage	Black	White	Green	Amber Red
DF14406	Style 98 Hommage	White	Black	Blue-green	Amber Red

Main Features (for customer)

- Three gauges are fitted into one DIN size.
- The front cover of the gauge has flat face glass.
- Opening and Closing mode: The needle pointers of three gauges move sequentially.
- The three meters are angled towards the driver for a higher level of visibility.
- Stepping motor
 - Maximum angle 270° is controlled by the microcomputer up to 4,600 divisions(0.059°) to provide high precision in the accuracy of information generated.
 - Quick response which is sustainable in racing scenes.
- Bright transparent gauge dials and instrument needle pointers are used in the gauges to increase visibility at day and night.
- The lights are produced from super high bright LED lamps.
- Equipped with a peak hold function (Requires a commercially available switch if you use the function. Peak values are reset automatically when power is turned off).

Part Names and Dimensions in mm (inches)

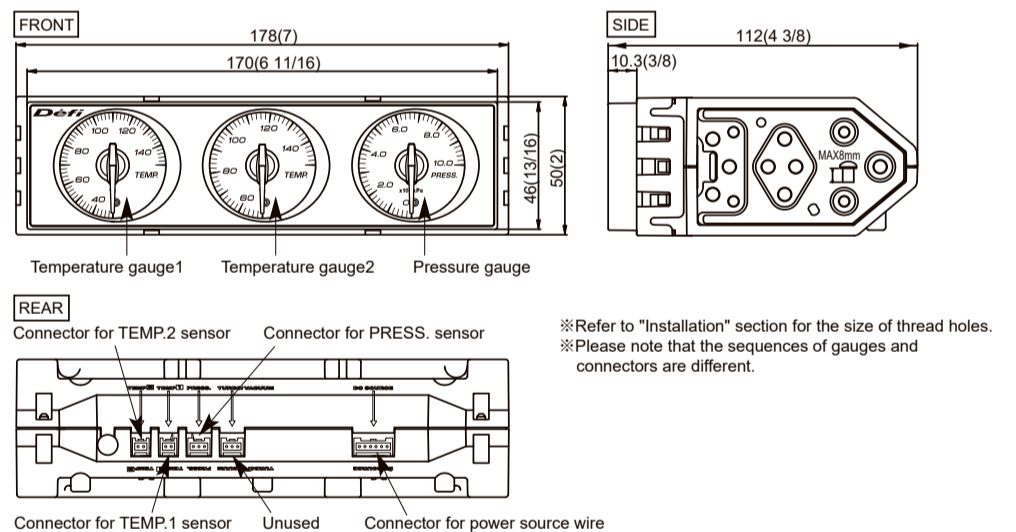

Product Specifications (for customer and installation personnel)

Power Supply Voltage	10V to 16V DC (For 12V vehicles)	
Current Consumption	+B line (red)	MAX 0.5A (Dark current 0mA)
	IGN line (orange)	MAX 0.5A
	12V-IN line (white)	MAX 5mA (0.1A or less during peak display)
Operational Temperature Range (under 80% relative humidity)	DIN-Gauge	-20 ~ +60°C, -4 ~ +140°F
	TEMP. sensor	-20 ~ +150°C, -4 ~ +302°F
	PRESS. sensor	-30 ~ +120°C, -22 ~ +248°F
Storage Temperature Range (under 80% relative humidity)	DIN-Gauge	-30 ~ +80°C, -22 ~ +176°F
	TEMP. sensor	-30 ~ +150°C, -22 ~ +302°F
	PRESS. sensor	-30 ~ +140°C, -22 ~ +284°F
Display Range	TEMP.1	30 ~ 150°C
	TEMP.2	50 ~ 150°C
	PRESS.	0 ~ 1,000kPa
Sensor Thread Size	TEMP. sensor	1/8PT
	PRESS. sensor	1/8PT

Parts List (for customer and installation personnel)

The following parts are included with this product. Confirm that all parts are present before installing the product. In addition, these parts are sold separately for part replacement, so contact your retailer for further information.

- ❗ Attachments and seal tapes for sensor installation are not included with the product. Please purchase separately.
- ❗ Start guide and a warranty card are included other than the parts listed below. Keep them at hand.

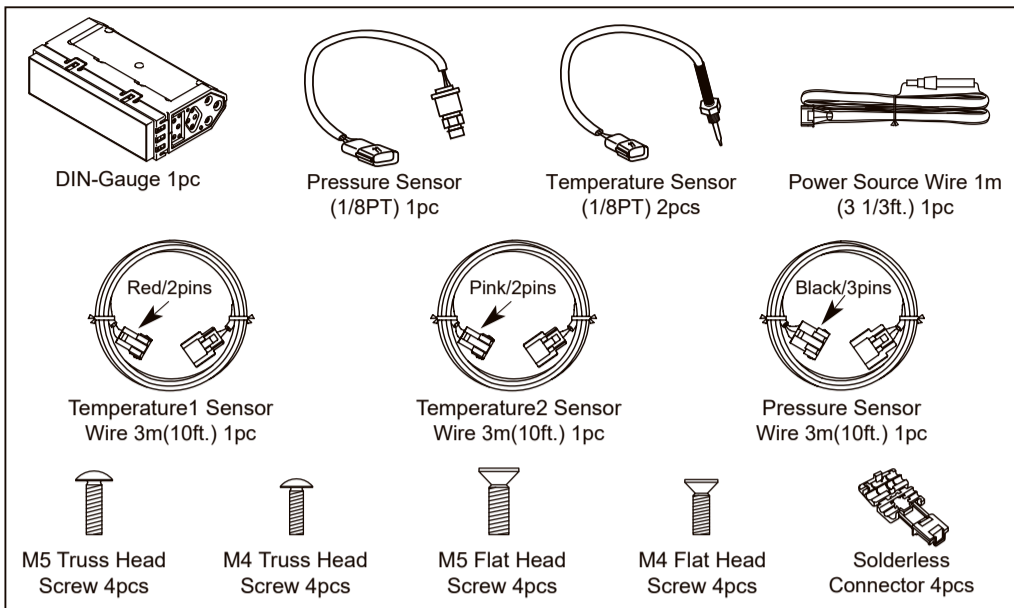

Repair Parts (for customer)

Item	Model Number
Pressure Sensor(1/8PT)	PDF00703S
Temperature Sensor(1/8PT)	PDF00903S
Temperature1 Sensor Wire 3m(10ft.)	PDF05602H
Temperature2 Sensor Wire 3m(10ft.)	PDF05603H
Pressure Sensor Wire 3m(10ft.)	PDF08105H
DIN-Gauge Power Source Wire 1m(3 1/3ft.)	PDF05601H
Fuse for Power Source Wire(1A) 2pcs	PDF07113G

Troubleshooting (for customer and installation personnel)



- ❗ If operation of the product seems unusual, inspect the product to confirm that there is no malfunction. If an operational problem has occurred, it could result in an accident.

※In addition to a general inspection of installation, use the following table to confirm proper operation of the unit.

Condition	Possible Cause	Corrective Action
○When the engine is turned off, the pointers of gauges don't point at the bottom.	○The battery wire (+B, red color) of the power source wire is not properly installed. ○The fuse is blown out.	○Check if the wiring is proper as per instructions in this manual. If the wire is installed properly, the pointers point at the bottom after the closing mode. ○Make sure the wiring is not touched on the vehicle body and then contact us.
○When the ignition key is turned on, the movement of the pointers are strange.	○DIN-Gauge carries out the opening mode. The check function is also carried out during the opening mode.	○This condition is normal; however, it means "wire disconnection" or "short circuit" when the pointer shakes at a regular interval after the opening mode. Refer to the "Operation" section and contact the retail outlet where the unit was purchased.
○The genuine water temperature gauge points a constant value, but the pointer of DIN-Gauge's water temperature continues to move.	○The genuine water temperature's pointer doesn't move at a certain value except in a dangerous conditions so as not to make the drivers nervous. DIN-Gauge's water temperature gauge points an accurate value.	○This condition is normal.
○The indication of water and oil temperature is not accurate. It indicates lower values.	○In the case that a conversion adapter or a Three-way joint is used between a sensor attachment and the sensor, sensors cannot measure the accurate temperature.	○Use a different type of attachment so that a conversion adapter is not necessary.
○Engine gets hot gradually, but water temperature indication begins to go up suddenly when a short time passes after the engine is started.	○This happens because the water temperature sensor is installed at an upper hose coming out from the radiator, and the thermostat opens to circular the coolants.	○This condition is normal.
○Gauge pointers move abnormally.	○Wiring is improper.	○Check wiring as per instructions in this manual.
○Does not operate.	○Wiring is improper.	○Check wiring as per instructions in this manual.
○The car condition is not good after installing the product.	○It may be caused by installation sensors.	○Ask the shop where the sensors were installed to recheck.
○TEMP1 (30°C~150°C) is connected to water temperature and TEMP2 (50°C~150°C) is connected to oil temperature, but the display is opposite.	○Connectors of sensor wires were inserted to incorrect connectors of DIN-Gauge.	○Check the position of connectors as per instructions in this manual.
○When the ignition key is turned off, the movement of the pointers is strange.	○DIN-Gauge carries out the closing mode.	○This condition is normal.
○After the opening mode, the pointer rises as the oil pressure rises, but the pointer does not fall when the oil pressure should have dropped.	○The white line of the power source wire is in contact with the 12V line and shows the peak value.	○By insulating the white line, the real value will be displayed. Or, by wiring the white line as described in [Wiring of power source wire], the peak value will be displayed only when the switch is on.

Installation (for installation personnel)

NOTE: The following illustration is an example for installation in Japanese vehicles. If this product is installed in vehicles made in other countries than Japan, please consult with a shop where it was purchased.

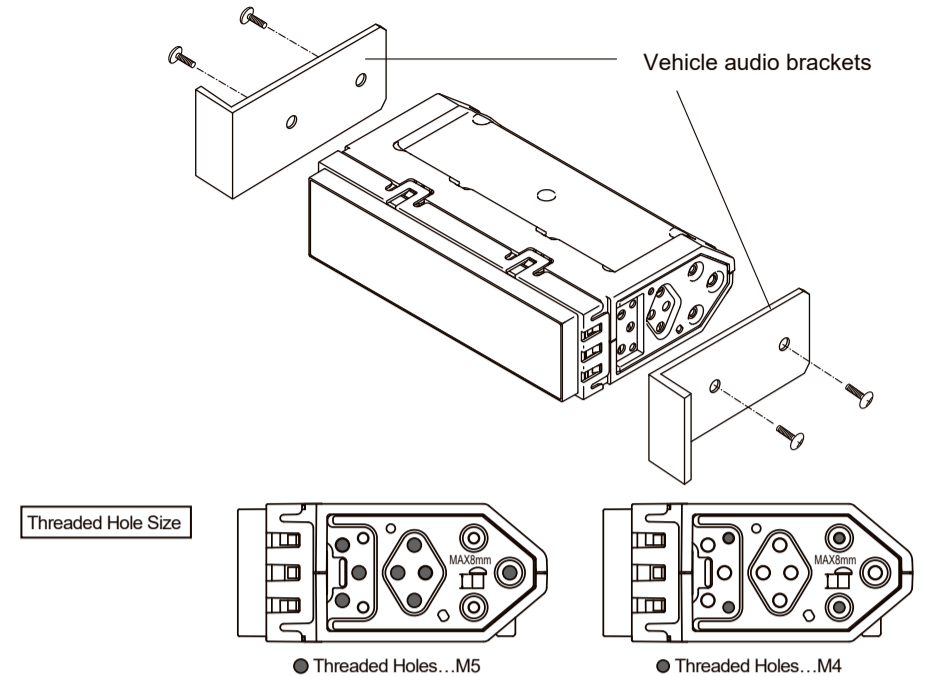

- Four kinds of screws (M5 truss head, M4 truss head, M5 flat head, and M4 flat head) are included. Please use any one of these kind of four screws.
- Depending on the type of car, a crevice may be made to the surroundings of DIN-Gauge. Please purchase a commercial face panel separately if needed.



- ❗ Carefully read the "Before handling" and "About Installation and Operation" sections of the manual concerning installation and operation. Then install the product properly and safely.
- ⊘ Do not connect any connector to the terminal stamped "TURBO/ACUUM."



- ⚠ The commercial audio brackets classified by the type of cars may be required separately.
- ❗ Be sure to use attached screws for installation. If long screws other than attachment are used, there is a possibility that the inside of DIN-Gauge may be damaged. Moreover, if a short screw is used, DIN-Gauge may separate from the DIN space of the vehicle. In addition, please use the screws which are suited vehicles from the four kinds of attached screws for installation.

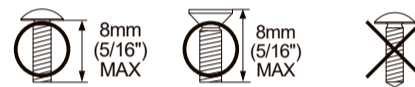

- ⚠ Depending on a type of car, the genuine vehicle brackets may have a positioning projection. Please flatten it with a hammer before installation.
- ⚠ Although the protection sheet is stuck on the glass surface, it may crack when sharp or hard instruments hit the glass or when DIN-gauge is dropped. Please install carefully.

[Wiring of power source wire]

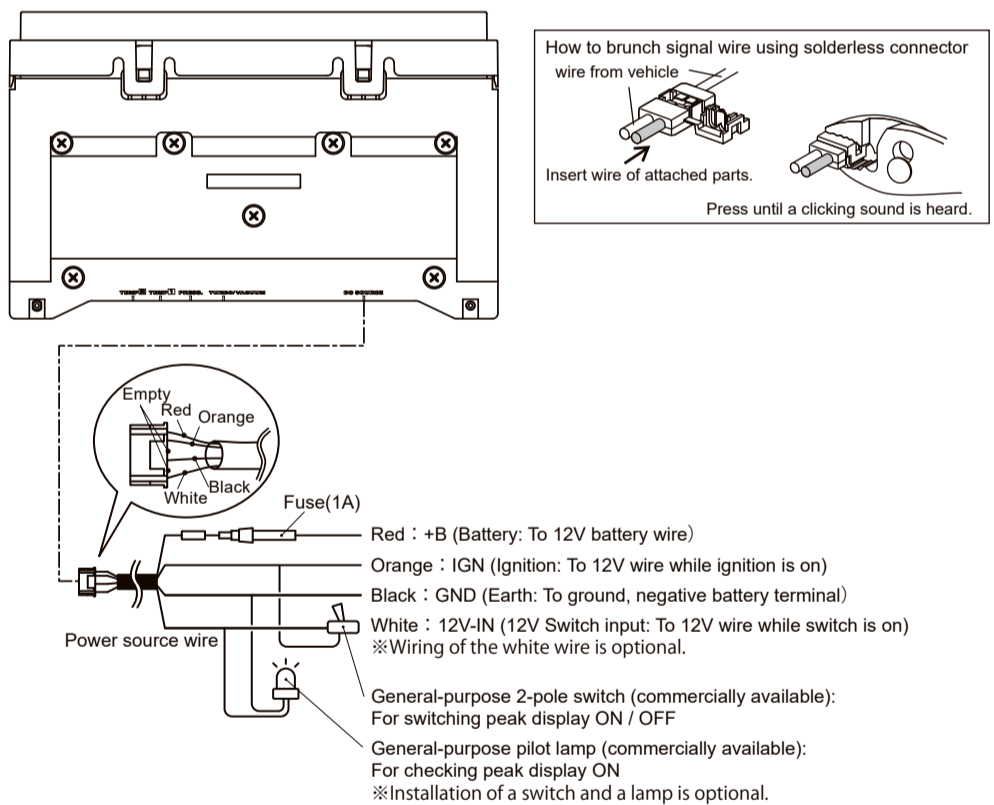

<Peak value display function>

By connecting a commercially available 2-pole switch, it is possible to switch the peak value display between ON and OFF. Furthermore, you can confirm that the peak display is ON by connecting a commercially available pilot lamp.
※Wiring of the white wire and installation of a switch and a lamp are optional. If you want to use this function, prepare commercially available parts. The switch and lamp wiring shown above is an example of installation. If you don't use the function, be sure to insulate the white wire to prevent problems.
※The peak value is maintained only the time from the power is turned on to off and automatically reset when the power is turned off.

[Connector position]

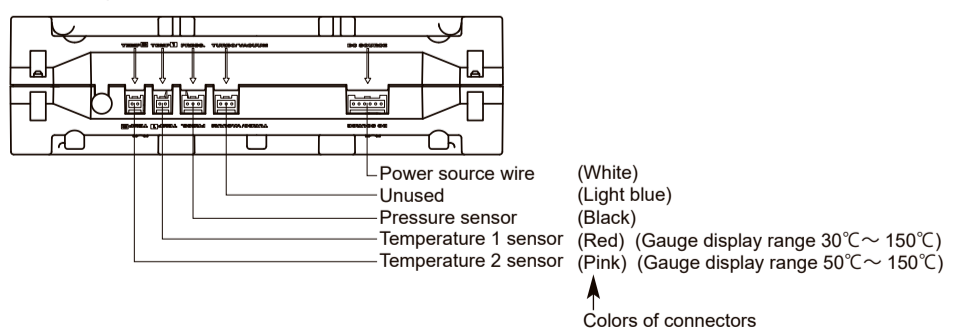

- ❗ Please insert the connector of the sensor wire in the correct connector of DIN-Gauge. Normal operation cannot be performed if the connection is wrong.
- ❗ Pull out each connector by pressing the lock firmly.
- ❗ If you do not use the white wire, be sure to insulate it.

How to attach pressure sensor (for installation personnel)

How to attach oil pressure sensor (Use a commercial sensor attachment.)

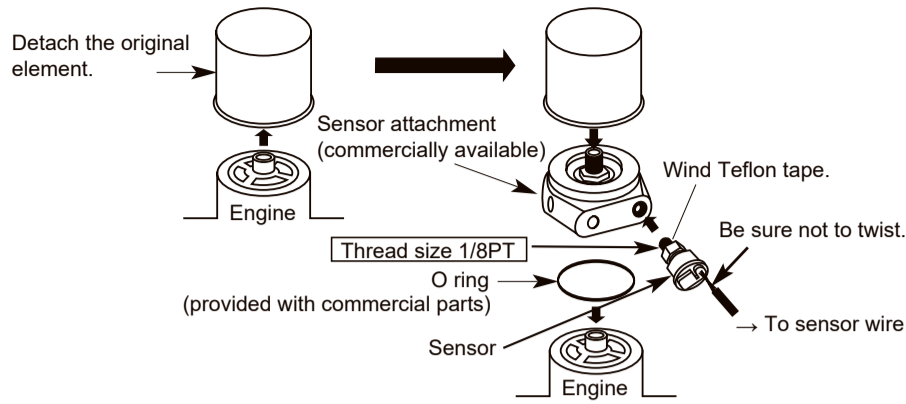

Warning

- ❶ Be sure the sensor wire is not twisted when installing the sensor. The sensor wire will be cut.
- ❷ Oil spills by the installation work. Please replenish the engine with oil. The engine might overheat when oil is too little.
- ❸ To avoid oil leaks by installing of the sensors, use Teflon tape. Before driving, inspect oil blocks for leaks. Leaks could cause a fire or damage the engine.
- ❹ Do not install the sensor near oil pump. Do not install the sensor to pressure switch directly. Failure to do so could damage the sensor because the pressure pulsation is too big and exceed three times full-scale momentarily.
- ❺ To avoid the damage of the sensor wire, please fix the waterproof connector on the vehicle body and do not bend the sensor wire near the sensor.

Confirmation

- ❶ The thread size of the pressure sensor is 1/8PT. Use a sensor attachment of 1/8PT.
- ❷ Tighten the sensor into the sensor attachment and then connect it to the sensor wire.

How to attach fuel pressure sensor (Use a commercial three-way joint and hose unions.)

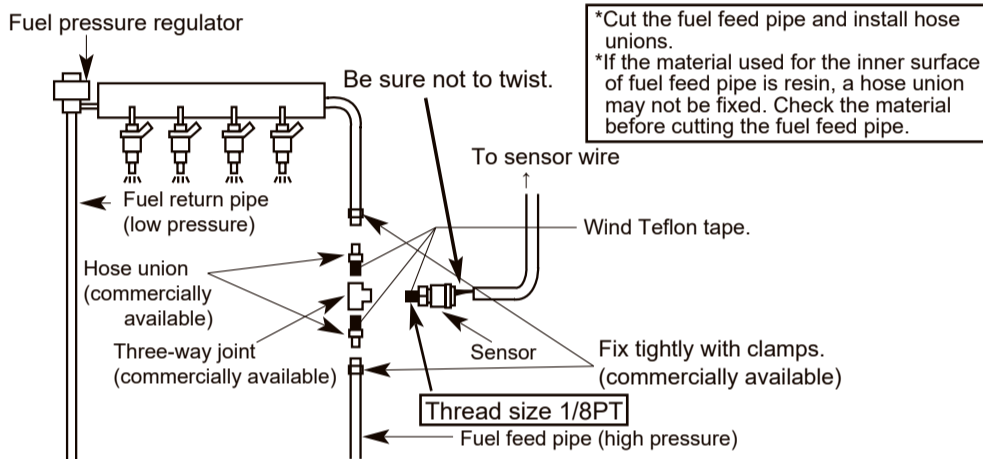

Warning

- ❶ Be sure the sensor wire is not twisted when installing the sensor. The sensor wire will be cut.
- ❷ Before cutting the fuel feed pipe, be certain to remove the gas cap to relieve any pressure built up in the fuel tank.
- ❸ When cutting the fuel feed pipe, be certain to discharge static electricity. Otherwise, there is a possibility of the ignition in gasoline.
- ❹ Wear glasses to protect eyes when cutting the fuel filter pipe.
- ❺ To avoid fuel leaks during installation of the sensor, use Teflon tape. Attach hose connection and fuel feed tubing with clamps. Inspect pipes and hose connections for leaks before driving.
- ❻ To avoid the damage of the sensor wire, please fix the waterproof connector on the vehicle body and do not bend the sensor wire near the sensor.

Confirmation

- ❶ The sensor must be installed on the feed (high pressure) pipe side between the fuel tank and the fuel pressure regulator.
※ It is not possible to obtain accurate fuel pressure from the return (low pressure) side at the rear of the fuel pressure regulator.
- ❷ The thread size of hose unions and the three-way joint need to be 1/8PT. Use hose unions and a three-way joint of 1/8PT.
- ❸ Tighten the sensor into the sensor attachment and then connect it to the sensor wire.

How to attach temperature sensor (for installation personnel)

How to attach oil temperature sensor (Use a commercial sensor attachment.)

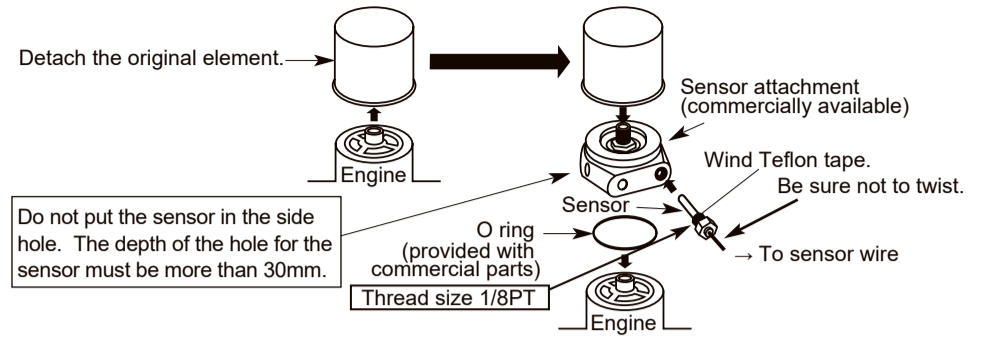

Warning

- ❶ Be sure the sensor wire is not twisted when installing the sensor. The sensor wire will be cut.
- ❷ Oil spills by the installation work. Please replenish the engine with oil. The engine might overheat when oil is too little.
- ❸ To avoid oil leaks by installing of the sensors, use Teflon tape. Before driving, inspect oil blocks for leaks. Leaks could cause a fire or damage the engine.
- ❹ To avoid the damage of the sensor wire, please fix the waterproof connector on the vehicle body and do not bend the sensor wire near the sensor.

Confirmation

- ❶ The thread size of the temperature sensor is 1/8PT. Use a sensor attachment of 1/8PT.
- ❷ The depth of the hole for the sensor must be more than 30mm.
- ❸ Tighten the sensor into the sensor attachment and then connect it to the sensor wire.

How to attach water temperature sensor (Use a commercial sensor attachment.)

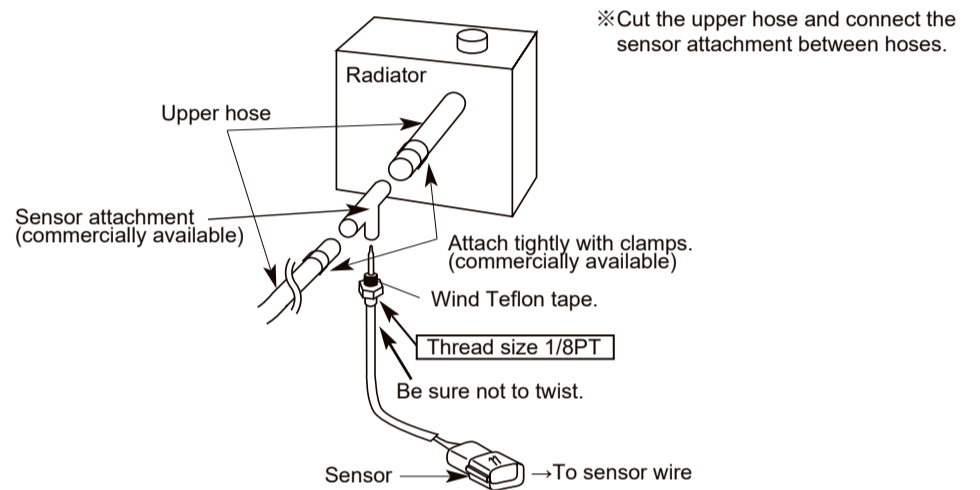

Warning

- ❶ Be sure the sensor wire is not twisted when installing the sensor. The sensor wire will be cut.
- ❷ Coolant spills by the installation work. Please replenish the engine with coolant and bleed the air from the system, or the engine might overheat.
- ❸ To avoid water leaks during installation of the sensors, use Teflon tape. Attach the sensor attachment and upper hose with clamps. Inspect hose connections for leaks before driving.
- ❹ To avoid the damage of the sensor wire, please fix the waterproof connector on the vehicle body and do not bend the sensor wire near the sensor.

Confirmation

- ❶ The thread size of the temperature sensor is 1/8PT. Use a sensor attachment of 1/8PT.
- ❷ Tighten the sensor into the sensor attachment and then connect it to the sensor wire.

Conversion Table (for customer)

Temperature	
°C	°F
0	32
10	50
20	68
30	86
40	104
50	122
60	140
70	158
80	176
90	194
100	212
110	230
120	248
130	266
140	284
150	302

Pressure	
kPa	PSI
0	0.0
50	7.3
100	14.5
150	21.8
200	29.0
250	36.3
300	43.5
350	50.8
400	58.0
450	65.3
500	72.5
550	79.8
600	87.0
650	94.3
700	101.5
750	108.8
800	116.0
850	123.3
900	130.5
950	137.8
1000	145.0

Final Confirmation After Installation (for installation personnel)

⚠ Warning

- ❗ After installation, check that no materials or tools remain in the driver's seat or the engine compartment. If there are tools at the feet of the driver's seat, this may cause brake operation failure because of tools or materials caught under the brake pedal. If there are tools in the engine compartment, the engine may be damaged.
- ❗ Please be sure to check the following items. Otherwise, there is a possibility that a serious accident may occur.

- Ensure that all hoses and tubing are properly attached. Also ensure that there is no leakage of oil, fuel, water and exhaust.
- Check that the sensor and wires are not interfering with the engine.
- Ensure that devices associated with the ignition (i.e. ignition coil, distributor, plug cord, etc.) were not damaged or disconnected during the installation of the sensors and wires.
- Ensure that the DIN-Gauge and wires are tightly attached, so they don't come loose and hinder driving.
- Check that all wires disconnected from the vehicle during installation have been properly reattached.
- Ensure that the negative battery terminal is tightly attached. Close the hood properly.

This concludes the installation process.

Confirmation

- ❗ The protection sheet is stuck to the glass for protection. Please remove the sheet in the customer's presence after installation of the product.

Operation (for customer)

【Opening/Ending mode】

- Once the ignition key is turned on, gauges come into operation after the needle pointers of three gauges move sequentially (opening mode).
- Once the ignition key is turned off, gauge operations stop after the needle pointers of three gauges move sequentially (ending mode).

【Illumination】

- Back lighting is always on.

【Peak value display】

- By connecting a commercially available 2-pole switch, it is possible to display the peak value. The peak value is automatically reset when the power is turned off.

【Check Functions】

⚠ Warning

- ❗ Please check meters after starting the engine and be sure there are no abnormalities in the car's function. If you start to drive without checking, there is a possibility an accident may occur.

Wire disconnections and short circuits of sensors and sensor wires can be checked by movement of pointers. If the pointers move as follows after installation of the product, please contact the installation personnel.

WIRE DISCONNECTION CHECK

This function reports the wrong wiring and/or disconnected sensors and wires. The pointer of a gauge which the wire is disconnected moves between 250° and 260° at the same interval.

※ The following illustration shows the angle of pointers. All the pointers of three gauges do not move simultaneously.

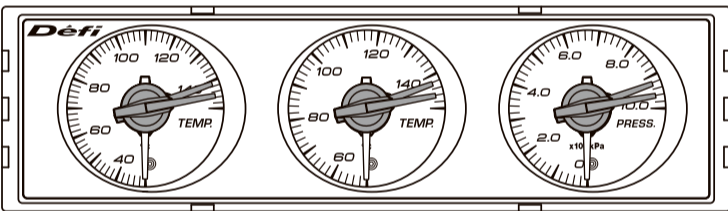

SHORT CIRCUIT CHECK

This function reports the short circuits of sensors and wires. The pointer of a gauge which has a short circuit moves between 10° and 20° at the same interval.

※ The following illustration shows the angle of pointers. All the pointers of three gauges do not move simultaneously.

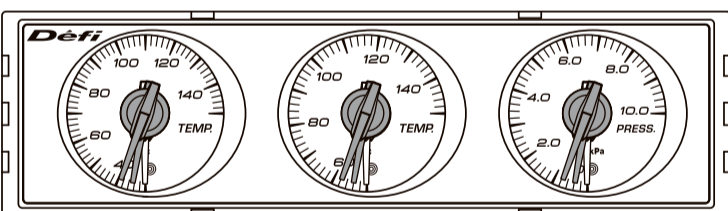

Maintenance & Check/Warranty & Servicing

■ Warranty card · Terms and conditions

This product is delivered with this operation manual and a warranty card. Please read terms and conditions in this manual thoroughly and keep the warranty card in a safe place. Failure to show this warranty will void the warranty.

■ Warranty period

Limited one year warranty. The warranty period starts at the date of retail purchase by the original end-user purchase. Please confirm the warranty card is provided with the information of retail store where purchased. Please refer to Limited Warranty for details.

⚠ Except in the case of defects, we shall not be liable for any trouble including violation, accident or improper wiring resulting from using this product.

- The warranty does not cover any unauthorized repair performed or caused to be performed by the end user. Such action can destroy or damage this product.

■ Inspection

Please ask the shop you purchased the product for inspection if any defect in product is suspected. We don't accept the order of fixing because Defi products require installation and wiring to the vehicle. In case you cannot go to the shop you purchased because of move-out or closure of shop, please ask the nearest Defi Distributor listed in the Defi website.

- ❗ For a repair/inspection service, take the warranty card and customer contact information with you.

Please conduct periodic inspections by Defi through a shop which sells Defi products or Defi's official distributor every five years. Inspection is available at an additional cost. In the case you purchase used products or used vehicles with products of Defi, please have an inspection by Defi as well before using them.

■ Label

The label stucked on the product is for the product traceability. Do not peel it off.

■ Repairing

When a repair is necessary, we will return the inspection result report through the store to you. After receiving a repair service request, we start repairing. Ask the store how much it costs and how long it takes to repair.

■ Discarding the products

Please dispose products in accordance with disposal laws, state laws and local government. A recycle label on the package indicates that the package is recyclable.

Terms and Conditions (for customer)

LIMITED PRODUCT WARRANTY AND LIMITED PRODUCT LIABILITY

A. Limited Warranty

- Our sole obligation to you after the sale of a product is to replace, without charge, the product or any component thereof discovered to be defective within a period of one (1) year from the purchasing date (the "Warranty Period"). You accept sole responsibility for the proper assembly operation and regular maintenance of the product. This limited warranty is void if any product is damaged by accident, misuse, improper installation, or abuse, including tampering or damage in transit. Further, this limited warranty is void if you sell or otherwise transfer a product to a third party, regardless of whether the transfer takes place within the Warranty Period.
- Our liability to you resulting from the sale of any product, including liability for any latent defects found within the Warranty Period, shall not exceed the total purchase price paid for the product by you.
- YOU UNDERSTAND AND AGREE THAT WE MAKE NO REPRESENTATIONS OR WARRANTIES OF ANY KIND, EXPRESS OR IMPLIED AS TO ANY MATTER WHATSOEVER, INCLUDING THE CONDITION OF THE PRODUCT OR ANY COMPONENT PARTS THEREOF, ITS MERCHANTABILITY OR ITS FITNESS FOR ANY PARTICULAR PURPOSE AND YOU ACCEPT IT, "AS IS," "WHERE IS."
- You also understand that we are not granting any express warranties, other than those stated herein. These include only those warranties enumerated in paragraph A. a. There are no other express warranties granted anywhere in these terms and conditions of sale, and you understand and agree to this fact as part of the bargained for exchange of this sale. Nowhere else, except as stated in this paragraph, in this contract is there intended, by either party, for there to be any express warranties granted to you.
- EXCEPT AS OTHERWISE PROVIDED HEREIN, WE SHALL NOT BE LIABLE FOR DAMAGES, INCLUDING SPECIAL, INCIDENTAL OR CONSEQUENTIAL DAMAGES WHETHER IN CONTRACT OR IN TORT ARISING OUT OF OR IN CONNECTION WITH THE PERFORMANCE OF ANY PRODUCT OR ANY COMPONENT PART THEREOF OR ITS USE BY YOU, AND WE SHALL NOT BE LIABLE FOR ANY SPECIAL, INCIDENTAL OR CONSEQUENTIAL DAMAGES ARISING OUT OF OR IN CONNECTION WITH YOUR USE OF THE PRODUCT.
- The warranty on this product is void if the product is modified, changed, adjusted or damaged. This product is to be used only in the ways for which it is designed and marketed for, any deviations from the intended uses will void the warranty and will excuse any possible liability of ours.
- You accept sole responsibility for the proper assembly, operation and regular maintenance of the product. This limited warranty is void if the product is damaged, changed, altered, or modified by accident, misuse, improper installation, or abuse, including tampering or damage in transit or while in use. YOU HAVE MADE AN INDEPENDENT INVESTIGATION OF THE PURCHASED COMPONENTS AND HAVE RELIED SOLELY ON YOUR OWN INVESTIGATION, BARGAINING AND JUDGMENT IN REFERENCE THERETO. YOU ACKNOWLEDGE THAT YOU ARE NOT RELYING ON OUR SKILL OR JUDGMENT TO SELECT OR FURNISH GOODS SUITABLE FOR ANY PARTICULAR PURPOSE IN PURCHASING OUR PRODUCTS, YOU HAVE NOT RELIED OR ACTED UPON ANY REPRESENTATIONS OR WARRANTIES ON OUR PART NOT SPECIFICALLY SET FORTH HEREIN.
- This limited warranty gives you specific legal rights. You may also have other rights which vary from state to state. Some states do not enforce contractual limitations on how long an implied warranty lasts, when an action may be brought, or the exclusion or limitation of incidental or consequential damages, so the above limitations or exclusions may not apply to you.

B. Modification Strictly Prohibited

You understand and agree that any modification whatsoever, of the product, is strictly prohibited. You also agree not to modify the product in any manner regardless of whether such modification is material or immaterial. You also acknowledge that any modification of the product will void your limited warranty and bar you from any recovery or any remedy in a court of law or equity. Modification is strictly forbidden unless expressly authorized by our prior written approval. You agree not to make any modifications to the product and agree not to use any parts, components, or accessories in connection with the installation and use of the product that are not authorized and approved by us.

C. Indemnity and Release

- You understand and agree that many factors beyond our control affect the operational safety of the product, including but not limited to the installation of the product according to the instructions provided with the product.
- You also understand and agree that the installation of the product may involve the use of tools, equipment and construction methods which may present safety hazards which are beyond our control. You also understand and agree that the use of some of our products may create hazards and lower your ability to control your vehicle.
- You agree, as part of the bargained for exchange, to protect, indemnify, save harmless and release us, our authorized agents, employees, officers, directors and shareholders from and against all liabilities, obligations, claims, damages, penalties, causes of action, costs and expenses, imposed upon or incurred by or asserted against us or any assignees of ours, by you or any third party by reason of the occurrence or existence (or alleged occurrence or existence) of any use, installation, assembly, possession or operation of the product, any loss, damage or destruction of the product as of and after delivery (a "casualty occurrence"), and any other act or event relating to or caused by the product, including but not limited to, consequential or of the terms and conditions hereof, or any and all liability for property loss or damage, or any and all damage resulting from death or personal injuries, including loss of services which any person may sustain on account of, arising out of, or in connection with any use, maintenance, possession or operation of the product. In the event that any action, suit or proceeding is brought against us or any of our authorized agents, employees, officers, directors or shareholders by reason of any such occurrence, you will, upon our request and at your expense, resist and defend such action, suit or proceeding or cause the same to be resisted and defended by counsel designated and approved by us.

DIN-Gauge Style 21/Style 98 Hommage Operation Manual

■ Issue Third edition: January, 2024

■ Manufacturer Nippon Seiki Co., Ltd.

■ Contact Information Defi, Nippon Seiki Co., Ltd.

【Address】2-34 Higashi-Zaoh 2-chome, Nagaoka-shi, Niigata 940-8580 JAPAN

【URL】<https://www.defi-shop.com/>

【Facebook】<https://www.facebook.com/Defi.Gauges>

【Instagram】https://www.instagram.com/defi_ns_official/

【YouTube】<https://www.youtube.com/DefiNSOfficial>



【Facebook】



【Instagram】



【YouTube】

NIPPON SEIKI