

Manual



Defi-Link Meter ADVANCE CR
SI Series DF07801~DF09404

Defi-Link Meter ADVANCE RS
SI Series DF13501~DF14101
DF17901~DF18501

Defi-Link Meter ADVANCE BF
SI Series DF09901~DF10706
DF14701~DF14703

Defi-Link Meter ADVANCE A1
SI Series DF14801~DF15401
DF17401~DF17501

A1-E: 22.10-3

IMPORTANT

WEAR SAFETY GLASSES

This product functions with the Defi-Link ADVANCE Control unit. This product does not function alone. Please refer to the Defi-Link ADVANCE Control unit operation manual as well.

Thank you very much for purchasing our product.

This product is an additional product for providing information to automobile users about engine conditions and other important factors. Before installing and using the product, please read this manual and the warranty card thoroughly. All sections are for customers and installation personnels. After installation, please keep this manual and the warranty card for future reference. In the event that this product (or the vehicle in which it is installed) is lent to or transferred to another person, please be sure this operation manual and warranty card accompany the product.

Defi will not be held responsible for accidents or damages related to installation of this product.

When installing and operating this product, be sure to read the cautionary items in the operation manual for the vehicle in which this product will be installed in addition to the manual of this product. Please obtain a full understanding of the cautionary items and use the product accordingly. Before using the product, please confirm all the components are included in the package.

Safety Warning [Please read carefully.]

In this manual, the degree of hazard arising from actions such as improper operation is separated into the 3 levels "Danger," "Warning," and "Caution." In addition, instructions that must be followed for safe and proper use of this product as well as practices that must be maintained are marked with a "Confirmation" heading. Please read and become familiar with these sections.

	Danger	Indicates a hazard that could cause death or serious personal injury if the product is mishandled.
	Warning	Indicates a possibility of death or serious personal injury if the product is mishandled.
	Caution	Indicates a conceivable source of personal injury or damage to equipment if the product is improperly operated.
	Confirmation	Indicates an instruction that must be performed or practice that must be maintained.

Properties for safety warning

	Indicates attention needs to be paid. (Including warnings)
	Indicates restricted actions. (PROHIBITED actions)
	Indicates actions that need to be carried out. (MUST actions)

Before handling (for installation personnel)

- Danger**
 - Do not install the product at the wet places. It may result in a fire caused by an electrical short circuit.
 - Ensure that the vehicle will remain stationary and turn off the engine before installing this product. Failure to do so could result in a fire, and could make the vehicle move during installation.
 - Remove the key from the ignition and disconnect the negative (-) battery terminal prior to installation of this product. Failure to do so could result in a fire caused by an electrical short circuit.
 - Take care not to install this product in a way that interferes with safety equipment such as seat belts and air bag systems or vehicle operation equipment such as engine controls, steering wheel or brake systems. Interference with normal operation of the vehicle can result in an accident or fire.
 - Solder or use a solderless connector for wiring connections and make sure connections are insulated. In areas where there could be tension or sudden impacts on the wiring, safeguard the wiring with corrugated tubing or other shock absorbent material. Accidental shorts can cause fires.
 - When wiring power supply wire, to avoid the risk of electrical shock or fire, be sure to confirm that there is no disconnection or breakage of wire. Poor connection can result in short-circuit, electrical shock, fire, or other hazards.
 - The ignition-switched +12V(IGN) line must be connected to the vehicle's ignition-switched wire with a fuse of 30A or less. High-capacity fuse(more than 30A) will not blowout even with an abnormal current flow and may cause fire.
 - Discontinue use of this product if a blowout of the fuse has occurred. Continued use while the condition exists could result in an accident, fire, or damage to the vehicle.
 - Use a fuse of regulated capacity when the fuse of the power wire is changed. Using a fuse that exceeds regulated capacity may cause fire and affect the accuracy.
 - Discontinue use of this product if the product doesn't operate or operates improperly. Continued use while the condition exists could result in an accident or fire.

- Warning**
 - Do not disassemble or modify this product. Such actions will not only void the warranty but also damage or destroy the product.
 - Do not perform installation of this product immediately after the engine has been switched off. The engine and exhaust system are extremely hot at this time and can cause burns if touched.
 - Do not cut more than one wire at the same time when cutting wires. Cutting several wires together may destroy your ECU, ignition system and other engine management devices.
 - Do not install this product in the area where safety equipment such as airbags are mounted. This may cause more injuries in the event of an accident.
 - Carefully consider the installation location and driver's operation of the product before installation. Do not install this product where it interrupts driving and the safety devices of vehicle such as the airbag system.
 - Be sure not to install this product where it could fall. Improper installation or operation could cause the product to fall and damage the vehicle or cause serious danger by impeding driving.
 - Ensure that the wiring of this product does not have an adverse impact on the other wiring of the vehicle. Incorrect wiring may destroy your ECU, ignition system and other engine management devices. When tapping engine rev or speed signal from the ECU, please make sure to follow the procedure as below:
 - 1. Make sure that you have connected the power supply wire of the advance control unit.
 - 2. Confirm that the DC Source LED of the advance control unit is lighted with ignition on.
 - 3. Remove negative terminal connector from battery and tap engine rev or speed signal from ECU.
 - Keep children and infants away from the installation area. Children may swallow small parts or be injured in other ways.

- Caution**
 - Do not drop any of the components of this product. It may result in damage to the product.
 - Do not apply excessive force on switches/terminals. It may result in damage to the product.
 - Do not use wires other than the provided wires.
 - Do not place wires near the engine, exhaust pipe or turbine. It may result in damage or fusion of wires.
 - Do not pull the wires out of connectors forcefully. The connectors may be broken and the wires may be cut. When pulling out the wires, press the lock firmly and unclip the locks of connectors.
 - Do not install gauges into the passenger side or center of the dashboard. It doesn't meet vehicle safety standards.
 - Do not attach wires on the body of the vehicle or engine parts as this may result in damage to the product.
 - Do not expose the advance control unit to moisture, dust or direct sunlight, or place product directly in front of heat vents.
 - Set it up so that the equipment such as the wireless machines and cellular phones that emits electric waves should not touch the advance control unit. It may result in incorrect operation.
 - Install wires away from ignition and also radio signal frequency interference as this could cause the gauges to malfunction.
 - This product is designed for use on 12V vehicles. Do not install this product on vehicles with 24V systems.
 - Insulate any unused wires. If any wires or connectors loosen during installation, please make sure they are correctly reattached.
 - Make sure the waterproof processing is done when diverging wires in the engine compartment.
 - When installing the sensor, do not bend the wire near the sensor body.
 - Wear gloves to avoid burns when soldering and cuts when installing wires, sharp edges of parts.
 - Install sensors away from hot or wet places.
 - When using sunshade, put sunshade between products and windshield to avoid direct sun exposure.
 - Use a dry, soft cloth for cleanup. Do not use cleaners except for neutral detergent. It may damage the product.

- Confirmation**
 - Do not lay the gauge face down due to oil leakage. Angle "A" must be more than 90 degrees.
 - Be sure to follow all instructions in this manual to ensure safe installation and operation of the product.
 - After installation is complete, return this operation manual, warranty card, and the package to the customer along with the warranty.
 - Confirm with the car maintenance manual issued by the manufacturer when installing and detaching genuine parts.
 - Before tapping wires, check the voltage of the existing wire. After tapping the wire, check the voltage of the tapped wire again to confirm whether you have tapped into the proper place.
 - If car navigation system or car television is installed in vehicle, gauges and wires of this product need to be kept as far away as possible from the wiring and installing positions of car navigation system or car television. Failure to do so may result in interference of television display.
 - When the negative (-) battery terminal is disconnected, equipment such as clocks and audio components having internal memory may lose their memory data. Follow the operation manual of each component to reset data after installation of this product.
 - The gauge pointer may not be in the proper position when you purchase the product. Normal function will resume when power is connected.
 - On no event will Nippon Seiki Co., Ltd. be liable to you for any damages or losses of genuine parts for your vehicle while installing.

About Installation and Operation(for customer and installation personnel)

- Warning**
 - Do not disassemble or modify this product. Such actions will not only void the warranty but also damage or destroy the product.
 - Do not operate during driving.
 - Discontinue use of this product if the gauge doesn't operate, water gets into the unit, or smoke or a strange odor comes from the unit. If such a condition occurs, contact the sales outlet or installation personnel as soon as possible.
 - Continued use while the condition exists could result in an accident or fire.
 - Please have this product installed by a retail store or dealer where it was purchased. Installation by the customer will void the warranty.
 - In order to ensure safe driving, check the information on the gauge only for short periods of time. Looking at the display for long periods of time could distract adequate attention from the road and result in an accident.
 - Fix the switch unit and other parts tightly to the vehicle to avoid that children swallow those.

Caution

- Do not pull the wires out of connectors forcefully. The connectors may be broken and the wires may be cut. When pulling out the wires, press the lock firmly and unclip the locks of connectors.
- On no event will Nippon Seiki Co., Ltd. be liable to you for any damages arising out of the use or inability to use the product, even if Nippon Seiki Co., Ltd. has been advised of the possibility of such damage.

Confirmation

- This product cannot be linked to the Defi-Link System.
- Do not connect more than one gauge of the same variety. (Ex. You can NOT connect 2 turbo gauges together.)
- The information displayed on this product are for reference purposes only. Please drive according to the indication of vehicle's originally equipped instruments.
- Please check the installed product regularly. Durability might deteriorate according to use conditions, etc.
- Dispose of the product according to the local recycling regulations.
- This product uses high luminance LEDs. When several gauges are lined up, there might be color difference in the LED production tolerance, but it is not malfunction.
- In the case of idling stop vehicles, the power of the product is turned off and restarted in some cases by a drop in battery voltage when the engine is restarted while idling stop function is active. It is not malfunction.
- This product can be used only on 1, 2, 3, 4, 5, 6, and 8 cylinder vehicles with 4 cycle engine. This product cannot be used on diesel vehicles.

Features (for customer)

- The advanced system (interactive communication) is implemented.
- Operation from distance is enabled using a remote control switch unit.
- Flat glass, high-definition scale and long, narrow pointer provides accurate indication and high visibility.
- The opening mode and ending mode can be selected from two variations.
- To install additional gauges, you can just make connection between gauges and attach the wire from the sensor to the advance control unit.
- Our original stepping motor is used to enable a smooth, instantaneous response to high performance sport driving.
- The microcontroller calibrates up to 270° of deflection angle in 3072 to 4600 segments (0.088° to 0.059°) and provides accurate vehicle information.
- Self-diagnosis function detects a disconnection of wire, short circuit and communication error, and indicates the error condition with the warning LED.
- A warning value (arbitrary) can be set. Buzzer sounds when the warning LED (red) is turned on (buzzer sound can be turned on/off).
- Data obtained during driving (peak value and warning value) can be stored up to three minutes, and the data can be replayed after driving.
- A dedicated mounting bracket and meter cup are provided as standard equipment.
- With both fuel pressure gauge and turbo installed, differential pressure can be displayed on the fuel pressure gauge. (not available for Turbo 3.0 models)
- The illumination of ADVANCE gauges is controlled automatically by connecting ADVANCE FD/ZD to the ADVANCE system.
- The illumination color at night can be switched between two different colors. (CR/RS)
- The outer edge of the glass is illuminated in red in a ring shape at night. (CR)
- A regular position bezel is included as a standard equipment. (CR)
- The light-emitting gauge always provides clear visibility with high contrast. (BF/A1)
- Low reflection glass for A1 gauges provides high visibility. (BF/RS/Φ60)
- Brightness can be adjusted by selecting from five levels for daytime and nighttime separately. Nighttime dimming cancellation function is available. (BF/A1)

Lineup (for customer)

Product Name	Product No.
Defi-Link ADVANCE Control unit	DF07703

- Do not connect more than one gauge of the same variety. (Ex. You can NOT connect 2 turbo gauges together.)
- The advance control unit is necessary to operate ADVANCE gauges.
- One advance control unit can control up to 7 gauges.

Product name	Display range	RS Φ52	RS Φ60	CR Φ52/60
Turbo2.0	-100~+200kPa	Black Dial	Black Dial	White/Black Dial
Turbo1.2	-100~+120kPa			
In-Mani Press(※1)	-100~+20kPa	DF13601	DF18001	
Oil Press	0 ~ 1000kPa	DF13701	DF18101	
Fuel Press	0 ~ 600kPa	DF13801	DF18201	
Oil Temp	50 ~ 150°C	DF13901	DF18301	
Water Temp	20 ~ 120°C	DF14001	DF18401	
Exhaust Temp	200 ~ 1100°C	DF14101	DF18501	
Tachometer	0 ~ 9000rpm			

Product name	Display range	BF White Model	BF Amber Red Model	BF Blue Model	A1
Turbo3.0	-100~+300kPa	DF14701	DF14702	DF14703	DF14901
Turbo2.0	-100~+200kPa	DF09901	DF09902	DF09903	DF14801,02(※2)
Turbo1.2	-100~+120kPa	DF10001	DF10002	DF10003	
In-Mani Press(※1)	-100~+20kPa	DF10101	DF10102	DF10103	DF17401
Oil Press	0 ~ 1000kPa	DF10201	DF10202	DF10203	DF15001
Fuel Press	0 ~ 600kPa	DF10301	DF10302	DF10303	DF15101
Oil Temp	50 ~ 150°C	DF10401	DF10402	DF10403	DF15201
Water Temp	20 ~ 120°C	DF10501	DF10502	DF10503	DF15301,02(※2)
Exhaust Temp	200 ~ 1100°C	DF10601	DF10602	DF10603	DF15401
Tachometer	0 ~ 9000rpm	DF10704	DF10705	DF10706	DF17501

Product name	Display range	Amber Red Model
Boost	-30inHg~+29PSI	
Oil Press	0 ~ 145PSI	
Fuel Press	0 ~ 87PSI	
Oil Temp	122 ~ 302 °F	
Water Temp	68 ~ 248 °F	
Exhaust Temp	392 ~ 2010 °F	

- ※1: In-Mani Press is an abbreviation of Intake Manifold Pressure.
- ※2: Sensors, sensor wires, and sensor installation parts are not included in DF14802 and DF15302.

Dimensions and part names (for customer and installation personnel)

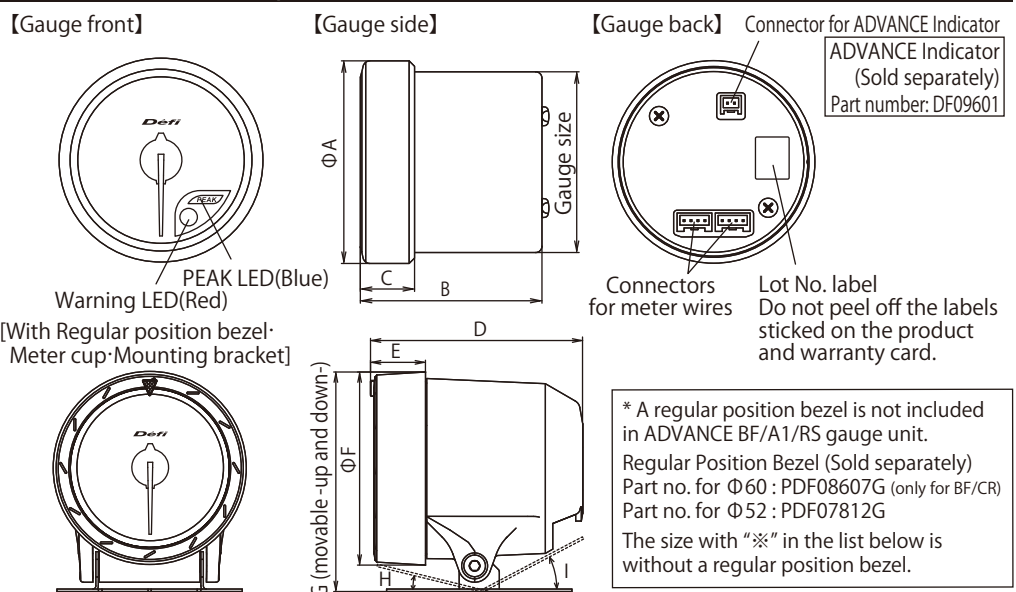

Gauge size				Unit : mm (inches)
CR/RS Φ52 (2 1/16")	CR Φ60 (2 3/8")	BF Φ60 (2 3/8")	RS/A1 Φ60	
A	58.3 (2.3")	66.3 (2.3")	66.3 (2.3")	66.3
B	52.2 (2.06")	52.2 (2.06")	52.2 (2.06")	54.6 (2.15")
C	15.5 (0.6")	15.5 (0.6")	15.5 (0.6")	17.9 (0.7")
D	68.6 (2.7")	68.6 (2.7")	65.9 (2.59")※	68.3 (2.69")※
E	17.8 (0.8")	17.8 (0.8")	—	—
F	62.5 (2.46")	70.5 (2.77")	—	—
G	69.6 (2.74") ~ 71.1 (2.8")	77.6 (3.05") ~ 79.1 (3.1")	75.5 (2.97") ~ 77 (3.03")※	75.5 (2.97") ~ 77 (3.03")※
H	15°	15°	18°※	18°※
I	28°	32°	32°※	32°※

Installation (for customer and installation personnel)

- Please refer to ADVANCE Control unit operation manual when installing gauges.
- Confirm all the components are included in the package.

How to wire mete wires

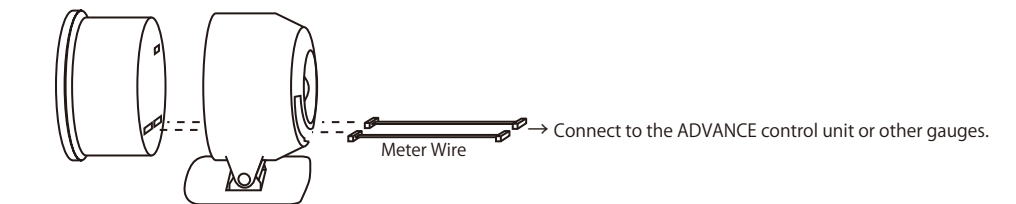

How to use the regular position bezel

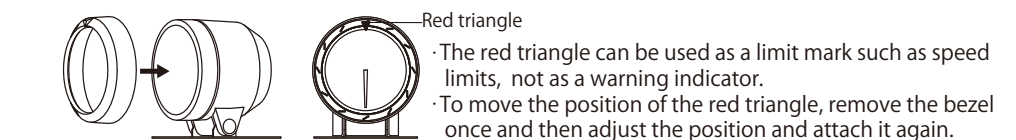

- *A regular position bezel is not included in ADVANCE BF/RS/A1 gauge unit. (Sold separately)
- *A regular position bezel cannot be attached with a single meter visor.

How to attach Mounting bracket set

- Cut the double sided tape (large) as shown in figure 1.
- Insert convex part of the mounting bracket over the legs of the meter cup. Attach the mounting bracket to the meter cup with the bolt, nut, and washer included in the kit as shown in figure 2.
- Attach one piece of double sided tape and the buffer on the gauge as shown in figure 3. (Cut the buffer into 16cm(6.3") when installing Φ52(2 1/16") series.)
- Pass the meter wires through the hole of the meter cup and connect them to the gauge.
- Place the gauge in the meter cup making sure that the wires are not sandwiched.
- Attach double sided tape on the back of the mounting bracket as shown in figure 4. Bend the mounting bracket to conform to the structure of the location where you intend to attach it.
- Fix the mounting bracket with commercial tapping screws as shown in figure 5.

- Confirmation**
 - Use appropriate dashboard cleaning liquids (commercially available) to clean the area where the double sided tape will be attached.
 - Do not lay the gauge face down due to oil leakage. Angle "A" must be more than 90 degrees.
 - Use commercial tapping screws with double sided tapes to fix gauges on dashboard.

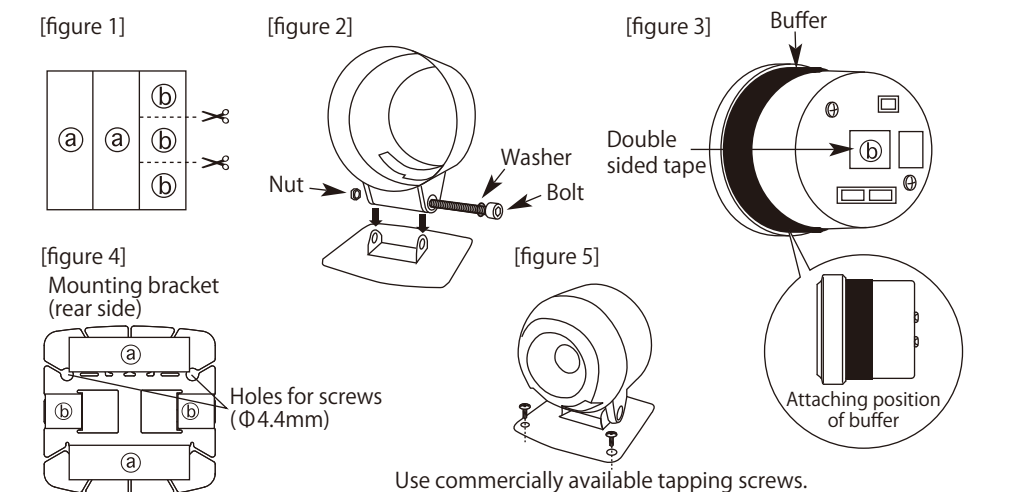

A mounting bracket cover is included in A1 gauges. In case you use it, peel one piece of the double sided tape (small) from WHITE release paper then put it on the center of the mount bracket. After that, overlay the cover. (Different adhesive materials are applied to each side.) The cover needs to be overlaid on tapping screws. Use the rest of the tape if necessary. The mounting bracket cover is not included in CR/BF/RS gauges. It is sold separately. (Mounting bracket cover part no. : PDF14803G)

Product Specifications (for customer and installation personnel)

- Power-supply voltage: 10V to 16V DC (12V vehicles only)
- Current consumption: the maximum value obtained when connecting seven gauges
 - +B wire: 2A (IGN ON) / 5mA (IGN OFF)
 - ILM wire: 800mA
- Temperature range (humidity is assumed to be 80% or lower) Unit: °C (°F)

Gauge	Temperature range for storage	Temperature range for operation
ADVANCE Control unit	-30 (-22) ~ +80 (176)	-20 (-4) ~ +60 (140)
Switch unit	-30 (-22) ~ +80 (176)	-20 (-4) ~ +60 (140)
Boost sensor	-30 (-22) ~ +80 (176)	-20 (-4) ~ +60 (140)
Pressure sensor	-30 (-22) ~ +100 (212)	-30 (-22) ~ +80 (176)
Temperature sensor	-30 (-22) ~ +140 (284)	-30 (-22) ~ +120 (248)
Exhaust temperature sensor	-30 (-22) ~ +150 (302)	-20 (-4) ~ +150 (302)
	-30 (-22) ~ +130 (266)	-30 (-22) ~ +130 (266)

- Temperature range (humidity is assumed to be 80% or lower) Unit: °C (°F)

CR	BF	RS	A1
outer edge and pointer: red	pointer: red	pointer: white (red at night)	pointer: white
night illumination: <white dial> amber red ↔ blue	illumination: white/amber red/blue	night illumination: classic green ↔ classic white	illumination: white
<black dial> white ↔ amber red	(The illumination color cannot be changed.)	(switchable between two colors)	(The illumination color cannot be changed.)

Turbo/Boost/In-Mani

Components

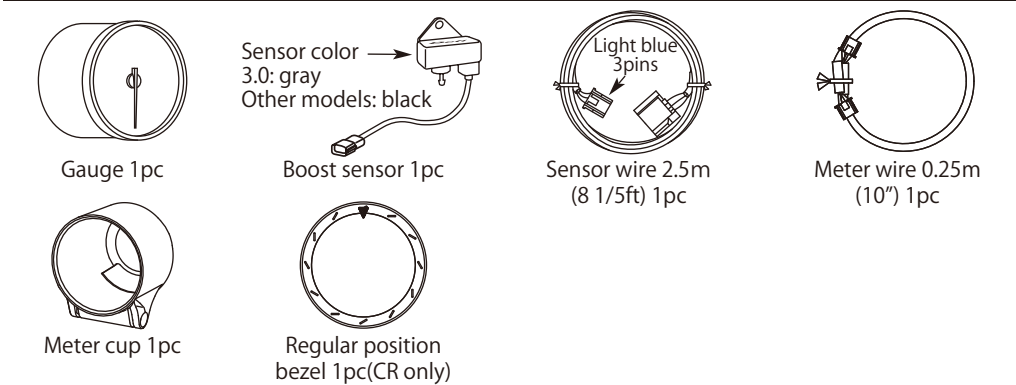

- Attachment parts for models other than Turbo 3.0
 - For inside diameter Φ4mm x 3
 - Inside diameter Φ4mm
 - Rubber hose and a three-way joint are not included in Turbo3.0. A rubber hose which has more than withstanding pressure of 400kPa (inner diameter Φ4mm) and a three-way joint which can match both the rubber hose and the vacuum hose size are required.
 - Do not use the rubber hose included in models other than Turbo 3.0 when installing Turbo 3.0 because it cannot withstand high pressure more than 200kPa.

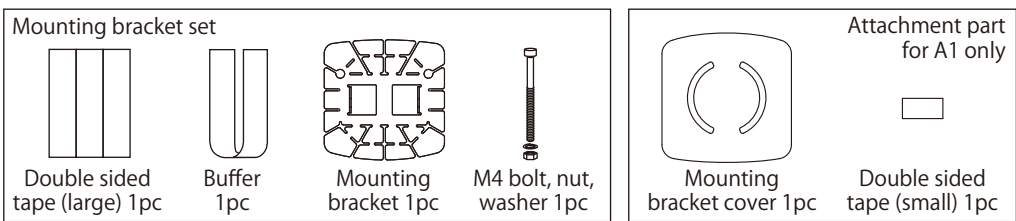

- Operation manual (this sheet) and warranty card are included other than the parts listed above. Keep them at hand.

How to attach boost sensor (e.g. for gasoline vehicle)

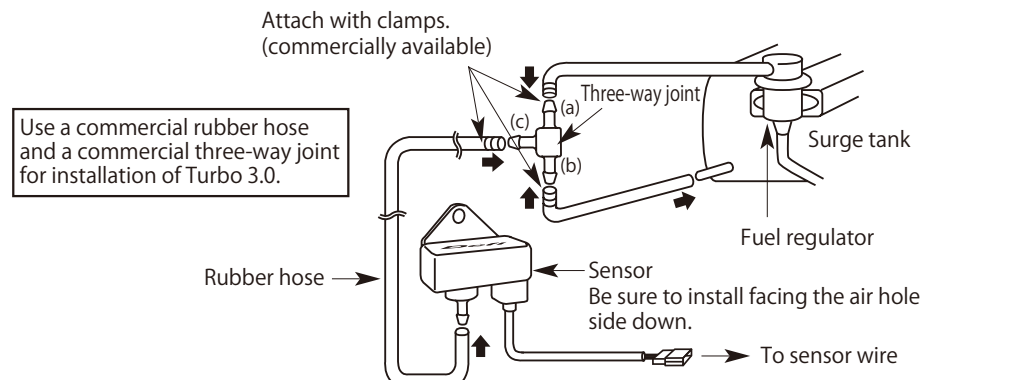

- The rubber hose attached to the sensor should be as short as possible. Attach the sensor with bolts (M6) in the engine compartment in an area where it will not be subject to excess heat or vibration.
- Access to the air pressure intake may be obtained between the surge tank and the fuel regulator.
 - Detach the vacuum hose from the surge tank side that has less pressure oscillations and connect it to the point (a) or (b) of the three way joint.
 - In order to connect the surge tank with three way joint, cut the required length of the hose from the included rubber hose.
 - Use the remaining rubber hose to connect the sensor to the three way joint.

- Warning**
 - Be sure to use commercial hoses which can withstand more than 400kPa for installation of Turbo 3.0. Failure to do so could cause serious damage to the engine, such as engine blowout or hose burst.
 - To avoid disconnection of rubber hose and air leak, attach hose clamps or use tie-wraps to secure the adjacent hose in the engine compartment. Disconnected hose or air leak could cause damage to the engine.
 - In the case that the gauge does not indicate correct intake pressure, shut off the engine immediately and stop using the product. Please recheck the wiring line. Air leaks or loose connections may happen, or the connected location may be wrong.

Confirmation

- The sensor must be installed being the rubber hose connection side faced down.
- For vehicles which have a solenoid valve between the surge tank and the fuel pressure regulator, place a three-way joint closer to the surge tank side than to the solenoid side.
- Depending on vehicle types, there are some cases that this product cannot be installed to a vehicle. Please ask retailers or distributors for details.
- The included three-way joint can be used only for the piping inner diameter of Φ4mm between the surge tank and fuel pressure regulator. In case of other than Φ4mm, use another joint that fits properly.

Caution for use of Turbo 3.0 (for customer)

- Offset function of the Defi-Link ADVANCE Control Unit is NOT available.
- The differential pressure display function is NOT available.
- When using it with the ADVANCE ZD, the setup values on the ADVANCE ZD and on the Turbo3.0 are different during setting the warning value. Use the value displayed on the turbo gauge for setting.
- Please refer to the manual of the Defi-Link ADVANCE Control Unit about functions above.
- Use the gray for the 3.0 turbo gauge and use the black sensor for 2.0 and under scale boost/ in-mani gauges for the normal operation.

OIL PRESS.

Components

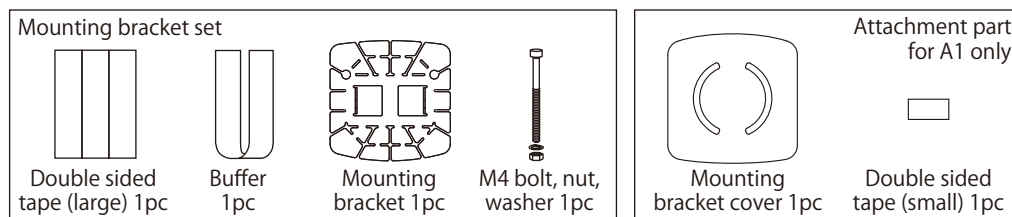
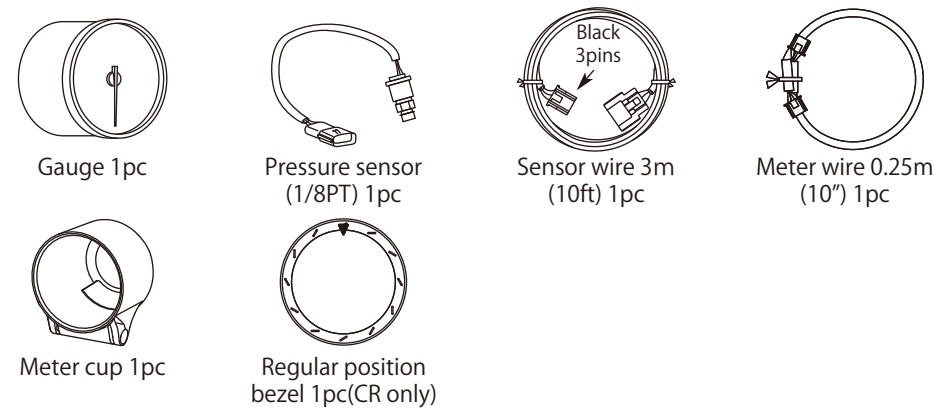

● Operation manual (this sheet) and warranty card are included other than the parts listed above. Keep them at hand.

How to attach pressure sensor (Use a commercial sensor attachment.)

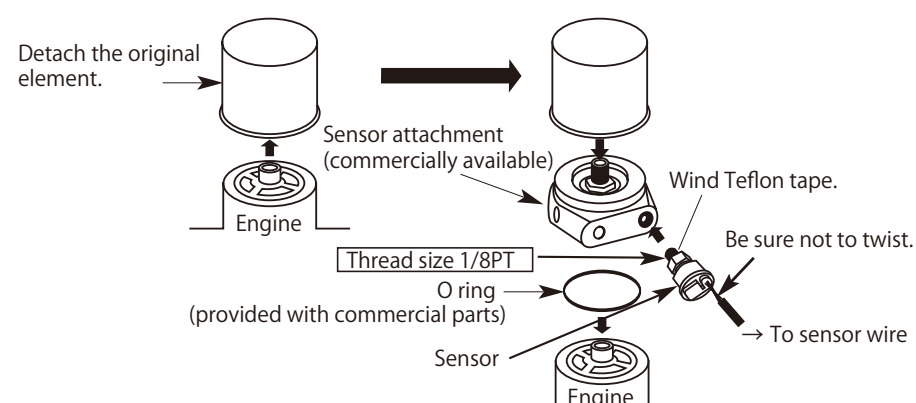

Warning

- Be sure the sensor wire is not twisted when installing the sensor. The sensor wire will be cut.
- Oil spills by the installation work. Please replenish the engine with oil. The engine might overheat when oil is too little.
- To avoid oil leaks by installing of the sensors, use Teflon tape. Before driving, inspect oil blocks for leaks. Leaks could cause a fire or damage the engine.
- Do not install the sensor near oil pump. Do not install the sensor to pressure switch directly. Failure to do so could damage the sensor because the pressure pulsation is too big and exceed three times full-scale momentarily.
- To avoid the damage of the sensor wire, please fix the waterproof connector on the vehicle body and do not bend the sensor wire near the sensor.

Confirmation

- The thread size of the pressure sensor is 1/8PT. Use a sensor attachment of 1/8PT.
- Tighten the sensor into the sensor attachment and then connect it to the sensor wire.

FUEL PRESS.

Components

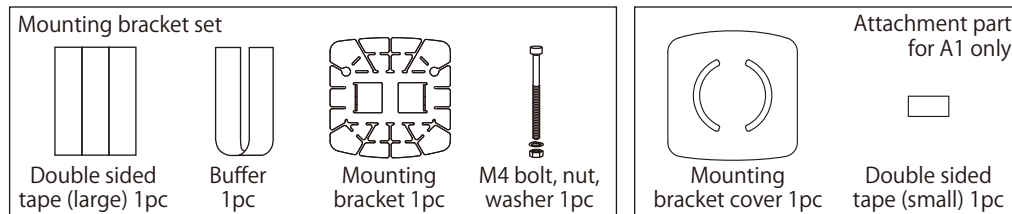
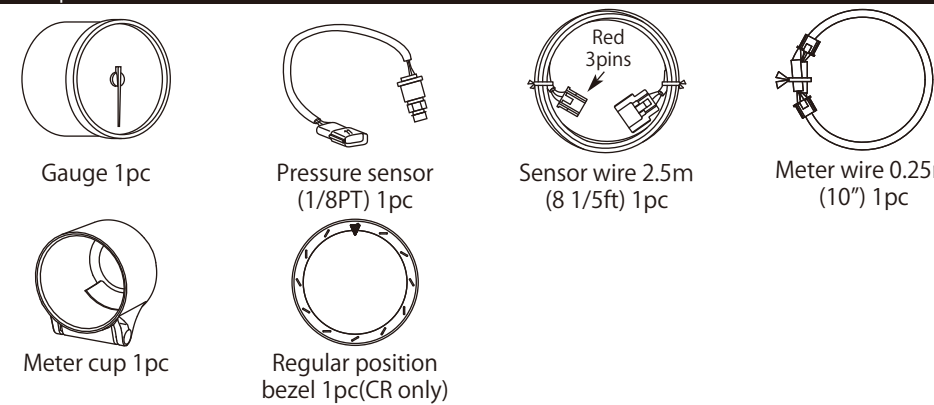

● Operation manual (this sheet) and warranty card are included other than the parts listed above. Keep them at hand.

How to attach pressure sensor (Use a commercial three-way joint and hose unions.)

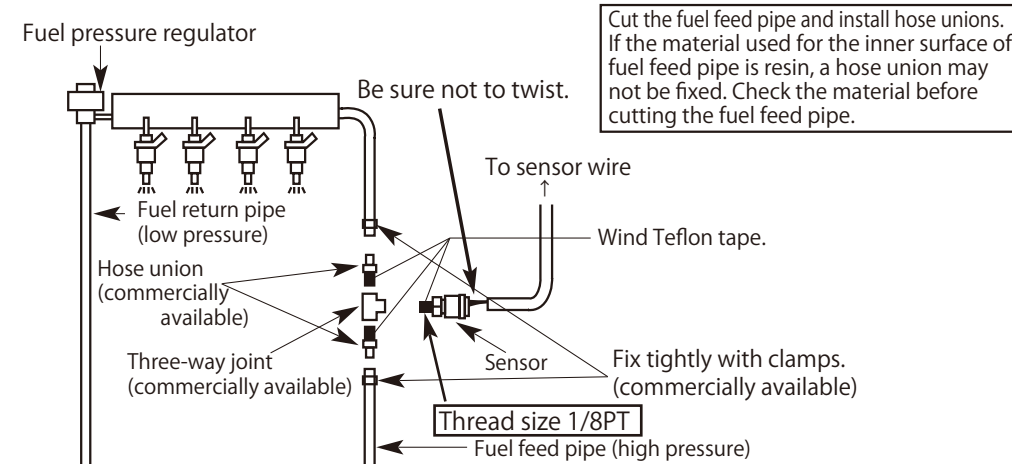

Cut the fuel feed pipe and install hose unions. If the material used for the inner surface of fuel feed pipe is resin, a hose union may not be fixed. Check the material before cutting the fuel feed pipe.

Warning

- Be sure the sensor wire is not twisted when installing the sensor. The sensor wire will be cut.
- Before cutting the fuel feed pipe, be certain to remove the gas cap to relieve any pressure built up in the fuel tank.
- When cutting the fuel feed pipe, be certain to discharge static electricity. Otherwise, there is a possibility of the ignition in gasoline.
- Wear glasses to protect eyes when cutting the fuel filter pipe.
- To avoid fuel leaks during installation of the sensor, use Teflon tape. Attach hose connection and fuel feed tubing with clamps. Inspect pipes and hose connections for leaks before driving.
- To avoid the damage of the sensor wire, please fix the waterproof connector on the vehicle body and do not bend the sensor wire near the sensor.

Confirmation

- The sensor must be installed on the feed (high pressure) pipe side between the fuel tank and the fuel pressure regulator.
- *It is not possible to obtain accurate fuel pressure from the return (low pressure) side at the rear of the fuel pressure regulator.
- The thread size of hose unions and the three-way joint need to be 1/8PT. Use hose unions and a three-way joint of 1/8PT.
- Tighten the sensor into the sensor attachment and then connect it to the sensor wire.

OIL TEMP.

Components

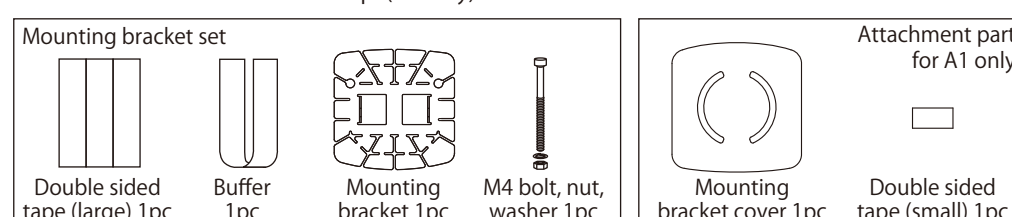
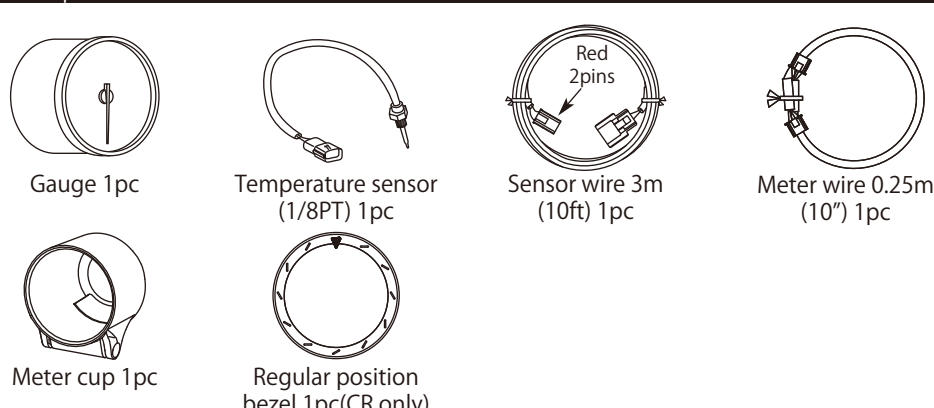

● Operation manual (this sheet) and warranty card are included other than the parts listed above. Keep them at hand.

How to attach temperature sensor (Use a commercial sensor attachment.)

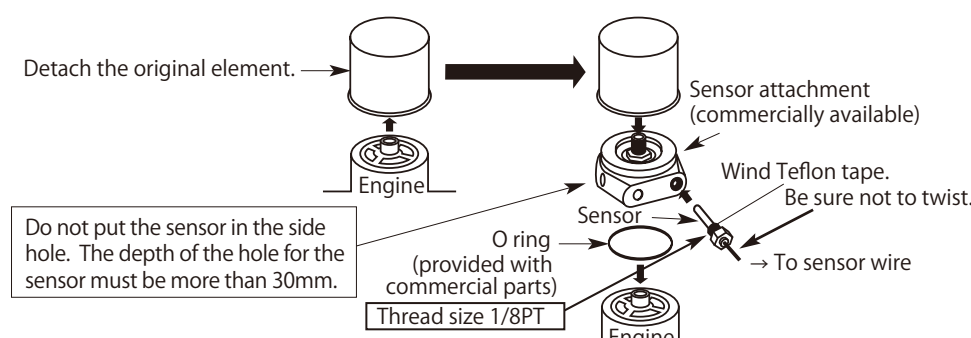

Warning

- Be sure the sensor wire is not twisted when installing the sensor. The sensor wire will be cut.
- Oil spills by the installation work. Please replenish the engine with oil. The engine might overheat when oil is too little.
- To avoid oil leaks by installing of the sensors, use Teflon tape. Before driving, inspect oil blocks for leaks. Leaks could cause a fire or damage the engine.
- To avoid the damage of the sensor wire, please fix the waterproof connector on the vehicle body and do not bend the sensor wire near the sensor.

Confirmation

- The thread size of the temperature sensor is 1/8PT. Use a sensor attachment of 1/8PT.
- The depth of the hole for the sensor must be more than 30mm.
- Tighten the sensor into the sensor attachment and then connect it to the sensor wire.

WATER TEMP.

Components

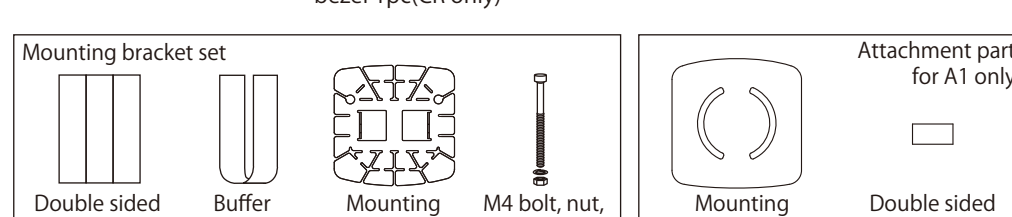
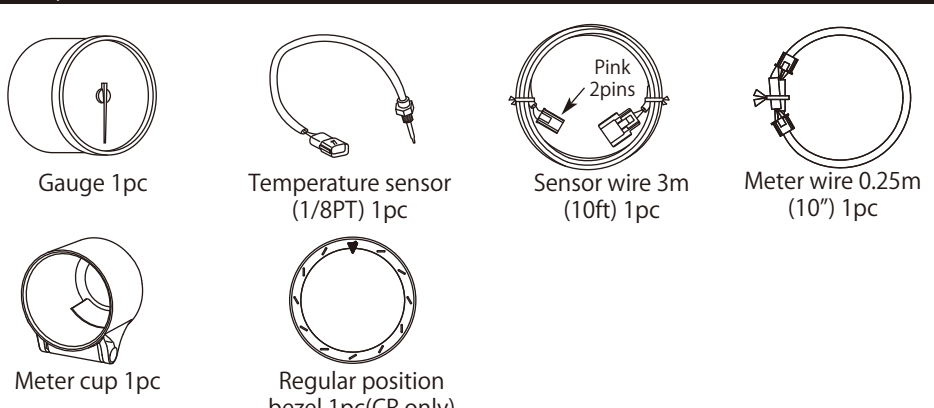

● Operation manual (this sheet) and warranty card are included other than the parts listed above. Keep them at hand.

How to attach temperature sensor (Use a commercial sensor attachment.)

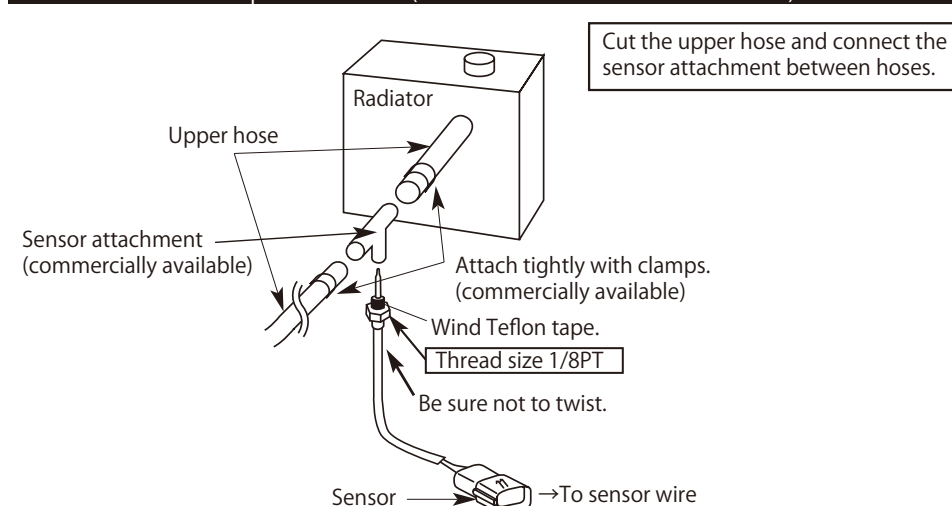

Cut the upper hose and connect the sensor attachment between hoses.

Warning

- Be sure the sensor wire is not twisted when installing the sensor. The sensor wire will be cut.
- Coolant spills by the installation work. Please replenish the engine with coolant and bleed the air from the system, or the engine might overheat.
- To avoid water leaks during installation of the sensors, use Teflon tape. Attach the sensor attachment and upper hose with clamps. Inspect hose connections for leaks before driving.
- To avoid the damage of the sensor wire, please fix the waterproof connector on the vehicle body and do not bend the sensor wire near the sensor.

Confirmation

- The thread size of the temperature sensor is 1/8PT. Use a sensor attachment of 1/8PT.
- Tighten the sensor into the sensor attachment and then connect it to the sensor wire.

EXHAUST TEMP.

Components

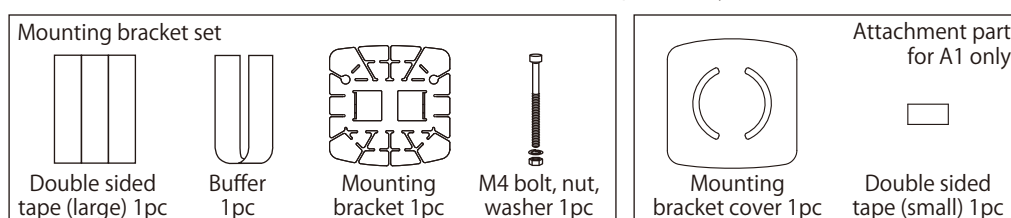
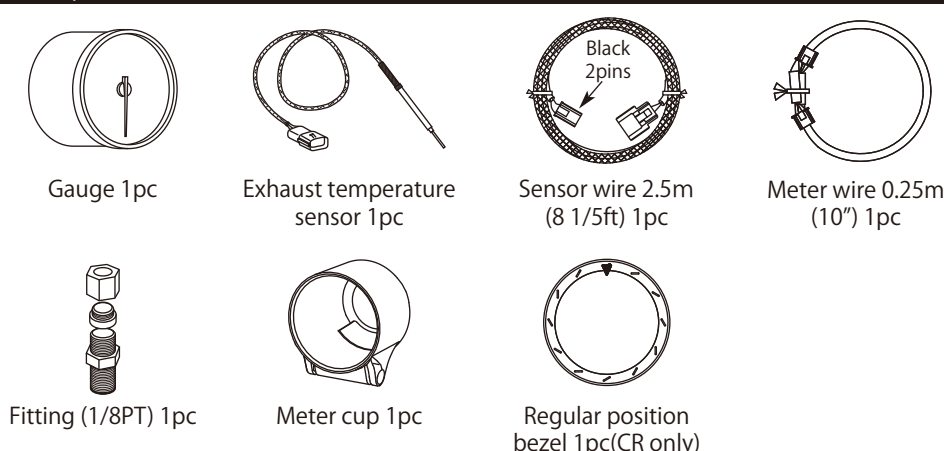

● Operation manual (this sheet) and warranty card are included other than the parts listed above. Keep them at hand.

How to attach exhaust temperature sensor for exhaust temperature

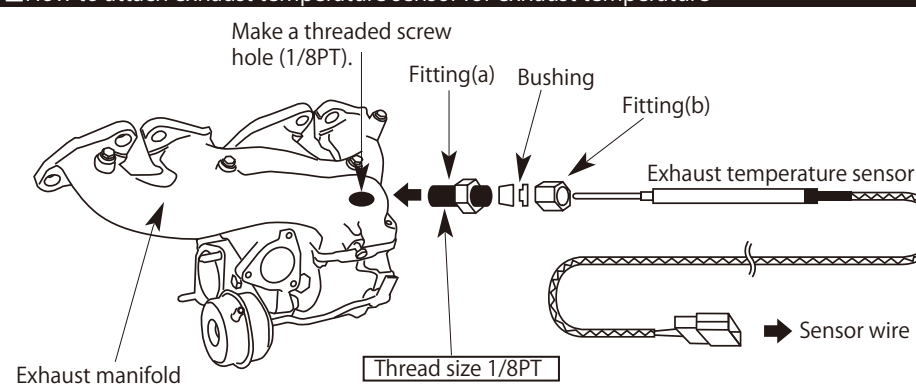

- 1) Make a 1/8PT threaded screw hole in the exhaust manifold pipe. (Weld if the pipe wall thickness is not enough)
- 2) Dismantle the fitting. Do not crush the bushing inside the fitting.
- 3) Tighten the fitting(a) to the hole of the exhaust manifold.
- 4) Pierce the sensor through the fitting(b) and the bushing.
- 5) Insert the edge of the sensor into the fitting(a) and position it at the center of the exhaust pipe.
- 6) Tighten the fitting(b).

Warning

- To avoid personal injury, do not install the exhaust temperature sensor while the engine is hot.
- When making a hole, make sure no chip remains in the exhaust pipe or turbine. It may result in damage to the engine, exhaust pipe, or turbine.

Confirmation

- The thread size of the fitting is 1/8PT. Make a threaded screw hole of 1/8PT.
- Tighten the sensor into the sensor attachment and then connect it to the sensor wire.

Tachometer

Components

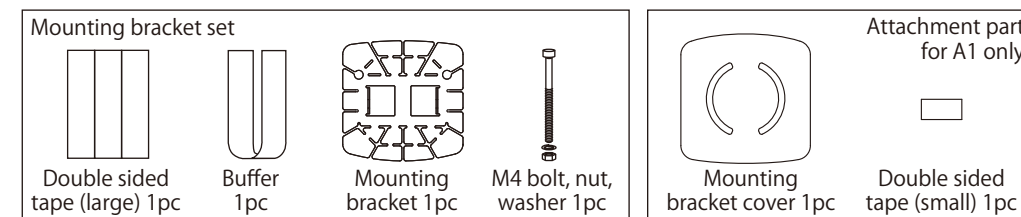
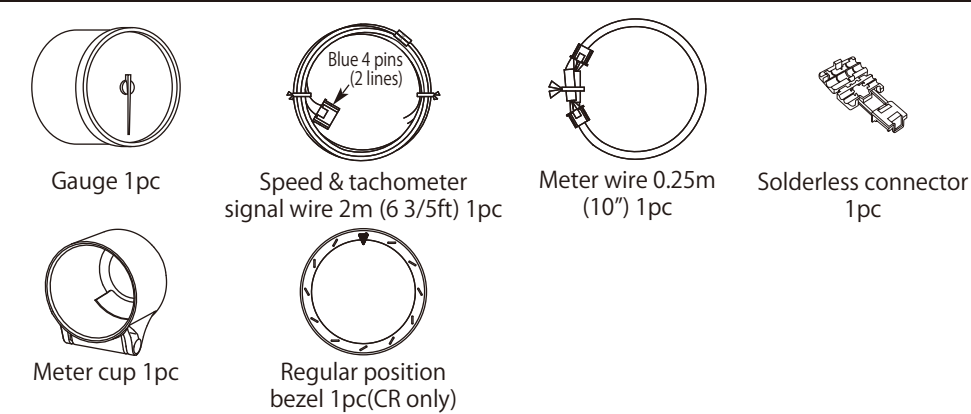

● Operation manual (this sheet) and warranty card are included other than the parts listed above. Keep them at hand.

How to wire speed and tachometer signal wire

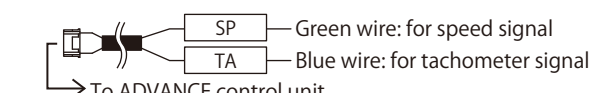

Connect the blue wire to tachometer signal wire of ECU of your vehicle. The TA signal needs to meet the requirements of the following graph.

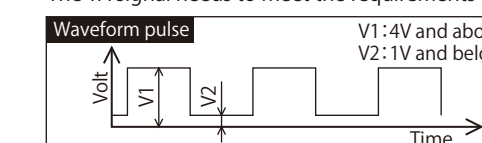

- 1) Connect the blue(TA) wire to tachometer signal of ECU of your vehicle.
- ⇒ Refer to "How to solder and use the solderless connectors" in Defi-Link ADVANCE Control unit operation manual.
- 2) If you use ADVANCE ZD with the tachometer, connect the green(SP) wire to speed signal of ECU of your vehicle. If you don't use ADVANCE ZD, insulate the unconnected wire.
- 3) Set the cylinder number and response according to Defi-Link ADVANCE Control unit operation manual.

Caution

- Make sure to insulate unconnected wire.

Factory default settings of warning values

Gauge	Default setting	Unit	Setting range		Lighting condition
			Minimum	Maximum	
Turbo 3.0	166.7	kPa	-100	300	Set value and above
	24.18	PSI	-14.5	43.5	
Turbo 2.0/1.2	100	kPa	-100	200	Set value and above
	14.5	PSI	-14.5	29	
In-Mani Press	10	kPa	-100	200	Set value and above
	1.45	PSI	-14.5	29	
Tachometer	7000	RPM	300	11000	Set value and above
	120	kPa	0	1000	
Oil press	17.5	PSI	0	145	Set value and below
	150	kPa	0	600	
Fuel press	21.8	PSI	0	87	Set value and below
	125	°C	0	150	
Oil temp	257	°F	32	302	Set value and above
	105	°C	0	150	
Water temp	221	°F	32	302	Set value and above
	850	°C	0	1100	
Exhaust temp	1562	°F	32	2010	Set value and above

● Please refer to the Defi-Link ADVANCE Control unit operation manual for installation, operation, troubleshooting, repair parts, optional parts, and terms and conditions.
○ The label stucked on the product is for the product traceability. Do not peel it off.

Defi-Link Meter ADVANCE CR/BF/RS/A1 Operation Manual

■ Issue Third edition: October, 2022

■ Manufacturer Nippon Seiki Co., Ltd.

■ Contact Information Defi, Nippon Seiki Co., Ltd.

[Address] 2-34 Higashi-Zaoh 2-chome, Nagaoka-shi, Niigata 940-8580 JAPAN

[URL] <https://www.defi-shop.com>

NIPPON SEIKI