

Manual for 80mm (3 1/8") diameter Tachometer



This product functions with the Defi-Link ADVANCE Control unit. This product does not function alone. Please refer to the Defi-Link ADVANCE Control unit operation manual as well.

Thank you very much for purchasing our product. This product is an additional product for providing information to automobile users about engine conditions and other important factors. Before installing and using the product, please read this manual and the warranty card thoroughly. All sections are for customers and installation persons. After installation, please keep this manual and the warranty card for future reference. In the event that this product (or the vehicle in which it is installed) is lent to or transferred to another person, please be sure this operation manual and warranty card accompany the product. Defi will not be held responsible for accidents or damages related to installation of this product. When installing and operating this product, be sure to read the cautionary items in the operation manual for the vehicle in which this product will be installed in addition to the manual of this product. Please obtain a full understanding of the cautionary items and use the product accordingly. Before using the product, please confirm all the components are included in the package. <http://www.defi-shop.com/>

Safety Warning [Please read carefully.]

In this manual, the degree of hazard arising from actions such as improper operation is separated into the 3 levels "Danger," "Warning," and "Caution." In addition, instructions that must be followed for safe and proper use of this product as well as practices that must be maintained are marked with a "Confirmation" heading. Please read and become familiar with these sections.

Danger	Indicates a hazard that could cause death or serious personal injury if the product is mishandled.
Warning	Indicates a possibility of death or serious personal injury if the product is mishandled.
Caution	Indicates a conceivable source of personal injury or damage to equipment if the product is improperly operated.
Confirmation	Indicates an instruction that must be performed or practice that must be maintained.

Properties for safety warning

	Indicates attention needs to be paid. (Including warnings)
	Indicates restricted actions. (PROHIBITED actions)
	Indicates actions that need to be carried out. (MUST actions)

Before handling (for installation personnel)

- Danger**
 - Ensure that the vehicle will remain stationary and turn off the engine before installing this product. Failure to do so could result in a fire, and could make the vehicle move during installation.
 - Remove the key from the ignition and disconnect the negative (-) battery terminal prior to installation of this product. Failure to do so could result in a fire caused by an electrical short circuit.
 - Take care not to install this product in a way that interferes with safety equipment such as seat belts and air bag systems or vehicle operation equipment such as engine controls, steering wheel or brake systems. Interference with normal operation of the vehicle can result in an accident or fire.
 - Solder or use a solderless connector for wiring connections and make sure connections are insulated. In areas where there could be tension or sudden impacts on the wiring, safeguard the wiring with corrugated tubing or other shock absorbent material. Accidental shorts can cause fires.
 - When wiring power supply wire, to avoid the risk of electrical shock or fire, be sure to confirm that there is no disconnection or breakage of wire. Poor connection can result in short-circuit, electrical shock, fire, or other hazards.
 - The ignition-switched +12V(IGN) line must be connected to the vehicle's ignition-switched wire with a fuse of 30A or less. High-capacity fuse(more than 30A) will not blowout even with an abnormal current flow and may cause fire.
 - Discontinue use of this product if a blowout of the fuse has occurred. Continued use while the condition exists could result in an accident, fire, or damage to the vehicle.
 - Use the fuse of regulated capacity when the fuse of the power wire is changed. Using a fuse that exceeds regulated capacity may cause fire.
 - Do not install the product at the wet places. It may result in a fire caused by an electrical short circuit.
 - Discontinue use of this product if the product doesn't operate or operates improperly. Continued use while the condition exists could result in an accident or fire.

Warning

- Carefully consider the installation location and driver's operation of the product before installation. Do not install the product where it interrupts driving and the safety devices of vehicle such as the airbag system. Be sure not to install the unit where it could fall. Improper installation or operation could cause the product to fall and damage the vehicle or cause serious danger by impeding driving.
- Do not disassemble or modify this product. Such actions will not only void the warranty but also damage or destroy the product.
- Do not perform installation of this product immediately after the engine has been switched off. The engine and exhaust system are extremely hot at this time and can cause burns if touched.
- Ensure that the wiring of this product does not have an adverse impact on the other wiring of the vehicle. Incorrect wiring may destroy your ECU, ignition system and other engine management devices. When tapping engine rev or speed signal from the ECU, please make sure to follow the procedure as below:
 - Make sure that you have connected the power supply wire of the advance control unit.
 - Confirm that the DC Source LED of the advance control unit is lighted with ignition on.
 - Remove negative terminal connector from battery and tap engine rev or speed signal from ECU.
- Do not cut more than one wire at the same time when cutting wires. Cutting several wires together may destroy your ECU, ignition system and other engine management devices.
- Please keep children and infants away from the installation area. Children may swallow small parts or be injured in other ways.
- Do not install this product in the area where safety equipment such as airbags are mounted. This may cause more injuries in the event of an accident.

Caution

- This product is designed for use on 12V vehicles. Do not install this product on vehicles with 24V systems.
- Insulate any unused wires. If any wires or connectors loosen during installation, please make sure they are correctly reattached.
- Do not drop any of the components of this product. It may result in damage to the product.
- Do not apply excessive force on switches/terminals. It may result in damage to the product.
- Do not use wires other than the provided wires.
- Do not attach wires on the body of the vehicle or engine parts as this may result in damage to the product.
- Install wires away from ignition and also radio signal frequency interference as this could cause the gauges to malfunction.
- Please set it up so that the equipment such as the wireless machines and cellular phones that emits electric waves should not touch the advance control unit. It may result in incorrect operation.
- Do not place wires near the engine, exhaust pipe or turbine. It may result in damage or fusion of wires.
- Make sure the waterproof processing is done when diverging wires in the engine compartment.
- When installing the sensor, do not bend the wire near the sensor body.
- Wear gloves to avoid burns when soldering and cuts when installing wires, sharp edges of parts.
- Do not expose the advance control unit to moisture, dust or direct sunlight, or place product directly in front of heat vents.
- Install sensors away from hot or wet places.
- When using sunshade, put sunshade between products and windshield to avoid direct sun exposure.
- Use a dried soft cloth for cleanup. Do not use cleaners except neutral detergent. It may damage the product.
- Do not pull the wires out of connectors forcefully. The connectors may be broken and the wires may be cut. When pulling out the wires, press the lock firmly and unclip the locks of connectors.
- Do not install gauges into the passenger side or center of the dashboard. It doesn't meet vehicle safety standards.

Confirmation

- Be sure to follow all instructions in this manual to ensure safe installation and operation of the product.
- When the negative (-) battery terminal is disconnected, equipment such as clocks and audio components having internal memory may lose their memory data. Follow the operation manual of each component to reset data after installation of this product.
- Do not lay the gauge face down due to oil leakage. Angle "A" must be more than 90 degrees.
- After installation is complete, return this operation manual, warranty card, and the package to the customer along with the warranty.
- The gauge pointer may not be in the proper position when you purchase the product. Normal function will resume when power is connected.
- Please confirm with the maintenance book on the car that the manufacturer issued when installing and detaching genuine parts.
- Before tapping wires, check the voltage of the existing wire. After tapping the wire, check the voltage of the tapped wire again to confirm whether you have tapped into the proper place.
- If car navigation system or car television is installed in vehicle, gauges and wires of this product need to be kept as far away as possible from the wiring and installing positions of car navigation system or car television. Failure to do so may result in interference of television display.
- On no event will Nippon Seiki Co., Ltd. be liable to you for any damages or losses of genuine parts for your vehicle while installing.

About Installation and Operation(for customer and installation personnel)

Warning

- Please have this product installed by the retail store or dealer where it was purchased. Installation by the customer will void the warranty. Do not disassemble or modify this product. Such actions will not only void the warranty but also damage or destroy the product.
- In order to ensure safe driving, check the information on the gauge only for short periods of time. Looking at the display for long periods of time could distract adequate attention from the road and result in an accident.
- Discontinue use of this product if the gauge doesn't operate, water gets into the unit, or smoke or a strange odor comes from the unit. If such a condition occurs, contact the sales outlet or installation personnel as soon as possible. Continued use while the condition exists could result in an accident or fire.
- Do not operate during driving.
- Fix the switch unit and other parts tightly to the vehicle to avoid that children swallow those.

Caution

- On no event will Nippon Seiki Co., Ltd. be liable to you for any damages arising out of the use or inability to use the product, even if Nippon Seiki Co., Ltd. has been advised of the possibility of such damage.
- Do not pull the wires out of connectors forcefully. The connectors may be broken and the wires may be cut. When pulling out the wires, press the lock firmly and unclip the locks of connectors.

Confirmation

- This product cannot be linked to the Defi-Link System.
- Do not connect more than one gauge of the same variety. (Ex. You can NOT connect 2 tachometers together.)
- The information displayed on this product are for reference purposes only. Please drive according to the indication of vehicle's originally equipped instruments.
- This product uses high luminance LEDs. When several gauges are lined up, there might be color difference in the LED production tolerance, but it is not malfunction.
- In the case of idling stop vehicles, the power of the product is turned off and restarted in some cases by a drop in battery voltage when the engine is restarted while idling stop function is active. It is not malfunction.
- Please check the installed product regularly. Durability might deteriorate according to use conditions, etc.

Lineup (for customer)

Product Name	Product No.
Defi-Link ADVANCE Control unit	DF07703

- The advance control unit is necessary to operate ADVANCE gauges. One advance control unit can control up to 7 gauges.

Tachometer Φ 80mm(3 1/8")	Product name	Display range	BF White Model	BF Amber Red Model	BF Blue Model	RS	A1
Tachometer	0 ~ 9000rpm	DF10901	DF10902	DF10903	DF14201		
Tachometer	0 ~ 11000rpm	DF11001	DF11002	DF11003	DF14301	DF15501	

The indicator for 80mm tachometer (PDF07108) can be installed additionally. The indicator is sold separately.

Product Specifications

- Power-supply voltage: 10V to 16V DC (12V vehicles only)
- Current consumption: the maximum value obtained when connecting seven gauges
 - +B wire: 2A (IGN ON)
 - 5mA (IGN OFF)
 - ILM wire: 800mA
- Number of cylinders supporting tachometer: 1, 2, 3, 4, 5, 6, 8 (4-cycle)
- Temperature range (humidity is assumed to be 80% or lower) Unit: (°C/°F)

	Temperature range for storage	Temperature range for operation
BF gauge	-30 (-22) ~ +80(176)	-20(-4) ~ +60(140)
Indicator (sold separately)	-30 (-22) ~ +80(176)	-20(-4) ~ +60(140)
- Illumination color
 - BF: white / amber red / blue ※The illumination color cannot be changed.
 - RS: switchable between classic green and classic white
 - A1: white
 - Indicator (PDF07108): green at warning setting ①, red at warning setting ②

Parts List (for customer and installation personnel)

The following parts are included with this product. Confirm that all parts are present before installing the product. In addition, these parts are sold separately for part replacement. Contact your retailer for further information. NOTE: Japanese operation manual is included other than the parts listed below. It is effective only in Japan.

Part Name	Quantity	Part Name	Quantity
Gauge	1	Mounting bracket	1
Back case	1	M6 bolt	2
Mounting band	1	Spring lock washer	2
Mounting rubber	1	Washer	2
Speed & Tachometer signal wire 2m, 6 3/5ft	1	Spacer	1
Meter wire 0.5m, 1 3/5ft	1	Buffer	1
Operation manual	1	Double sided tape	1
Warranty card	1	Tapping screw	2
		Solderless connector	1

Warning function of Φ 80mm tachometer

Two warning RPMs can be set at setting ① and ②. (There is one setting on Φ 60 tachometer.) When the RPM exceeds the set warning RPMs, the warning LED of tachometer lights up/blinks. The buzzer sounds if the buzzer of ADVANCE Control Unit is set ON. If an indicator for Φ 80 tachometer (sold separately) is installed, the indicator lights up in red/green at 2 settings being synchronized with warning LED of tachometer.

Order of gauge selection during warning setting

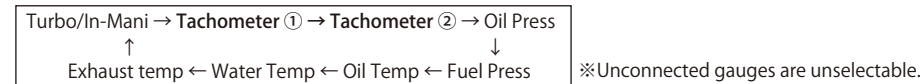

Setting the warning value

Regardless of the illumination status (ON/OFF), the dial illumination of selected gauge lights up with high brightness and the warning LED flashes, whereas the dial illumination of unselected gauge lights up with low brightness and the warning LED turns off. Refer to Setup mode/Set the warning value section in the operation manual of ADVANCE Control Unit for the detail.

Conditions of warning LED and indicator(sold separately) during warning setting

Tachometer① (Default : 7000rpm)	Warning LED : blinks / Indicator : lights up in green
Tachometer② (Default : 8500rpm)	Warning LED : blinks / Indicator : lights up in red

- The setting value ② needs to be higher than the setting value ①, and ① needs to be lower than ②.
- The indicator for Φ 80 tachometer is not included in the package of this product. It is sold separately. (PDF07108)
- The indicator for Φ 80 tachometer and ADVANCE Indicator are different. The ADVANCE Indicator cannot be attached to Φ 80 tachometer.

Warning display

[Scene A] When the RPM is lower than the warning setting①
The warning LED is off. The buzzer is off. The indicator is off.

[Scene B] When the RPM is higher than the warning setting①
The warning LED is on. The buzzer is off. The indicator is on in green.

[Scene C] When the RPM is higher than the warning setting②
The warning LED blinks. The buzzer beeps (a long beep). The indicator is on in red.
※The buzzer does not sound if the buzzer of ADVANCE Control Unit is set off.

Scene	Engine speed		
	Lower	Higher	Higher
Warning LED	[Scene A] Off	[Scene B] On	[Scene C] Blink
Buzzer (inside Control Unit)	Off	Off	long beep
Indicator (sold separately)	Off	On(green)	On(red)

Dimensions in mm(inches) and part names

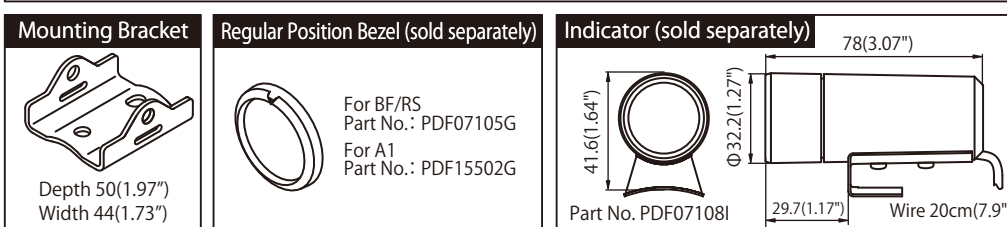
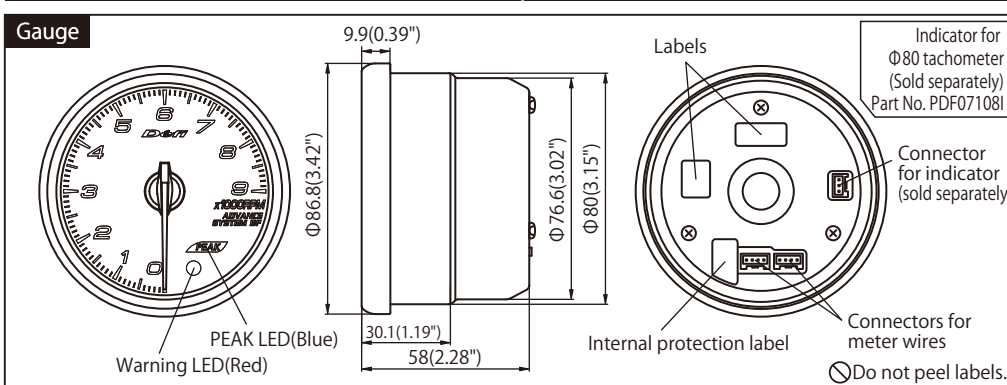

Assembling example ※Indicator is sold separately.

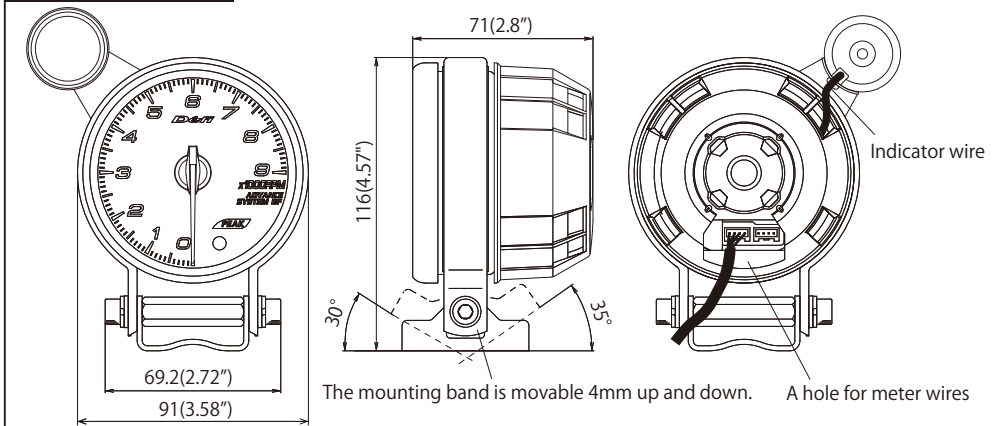

Installation

How to wire speed and tachometer signal wire

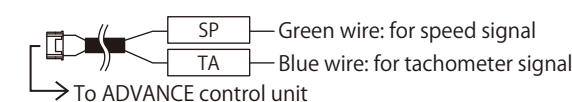

Connect the blue wire to tachometer signal wire of ECU of your vehicle. The TA signal needs to meet the requirements of the following graph.

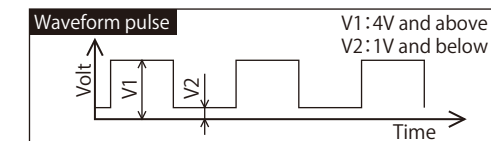

- Connect the blue(TA) wire to tachometer signal of ECU of your vehicle. →Refer to "How to solder and use the solderless connectors" in Defi-Link ADVANCE Control unit operation manual.
- If you use ADVANCE ZD with the tachometer, connect the green(SP) wire to speed signal of ECU of your vehicle. If you don't use ADVANCE ZD, insulate the unconnected wire.
- Set the cylinder number and response according to Defi-Link ADVANCE Control unit operation manual.

Caution

- Refer to the manual of ADVANCE Control Unit.
- Make sure to insulate the unconnected wire.

How to assemble

Indicator for Φ 80 tachometer is not included in this product. It is sold separately.

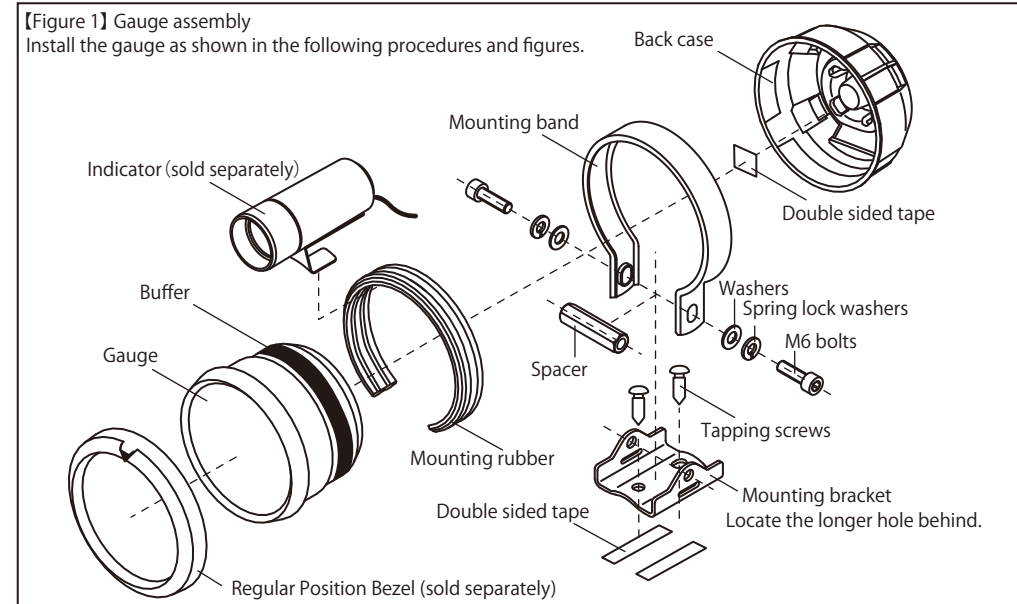

[Figure 1] Gauge assembly
Install the gauge as shown in the following procedures and figures.

- Attach the buffer around the gauge. [Figure 1]
 - Do not touch on the front face of the gauge so as not to put fingerprints.
- Fit the mounting rubber inside of the mounting band. [Figure 2]

- Fix the mounting band to the mounting bracket temporarily with the spacer, bolts, washers, and spring lock washers. Tighten bolts loosely by hands. Do not use a hexagonal wrench (Allen key) at this stage. [Figure 3]
- Fit the indicator into the mounting band. And then fit the gauge into the mounting band. Locate the indicator roughly at this stage. The indicator can be positioned in the range which it does not touch the mounting bracket and bolts. [Figure 4] [Figure 5]
 - Do not take hands off from the gauge so as the gauge does not fall down.

- Identify the position of the mounting bracket with the gauge fitted into the mounting band. Mark the shape of the mounting bracket and the position of the screw holes. [Figure 9]
 - To check that there is enough space for installation, identify the gauge position with the gauge and indicator fitted into the mounting band.
 - When setting the gauge angle, take care not to scratch by hitting the gauge to the mounting bracket.

- Disassemble the mounting band from the mounting bracket, and disassemble the gauge and indicator from the mounting band.
- Attach double sided tapes on the bottom of the mounting bracket. [Figure 1] [Figure 6]

- Fix the mounting bracket on the gauge installing position by using the tapping screws.
- Fit the indicator and gauge into the mounting band again. Take notice that the angle of the indicator cannot be changed while the bolts are fastened.

- Attach the double sided tape on the back side of the gauge. [Figure 1] [Figure 6]
- Pass the indicator wire through the hole of the back case from the outside. Connect the indicator wire to the connector on the gauge. [Figure 7]

- Put the back case on the gauge. Position the hole for the meter wire to the gauge connector for it. The indicator wire can be stored in the back space in the back case. [Part names/Assembling example]
- Fit the mounting band with the gauge in the mounting bracket by using a spacer, bolts, washer, and spring lock washer.
 - Depending on the installing space, it may difficult to fit the gauge. Do not pull wires forcefully and take notice not to hit the vehicle by parts.

- Fasten the bolts with a hexagonal wrench (Allen key) firmly. [Figure 8]

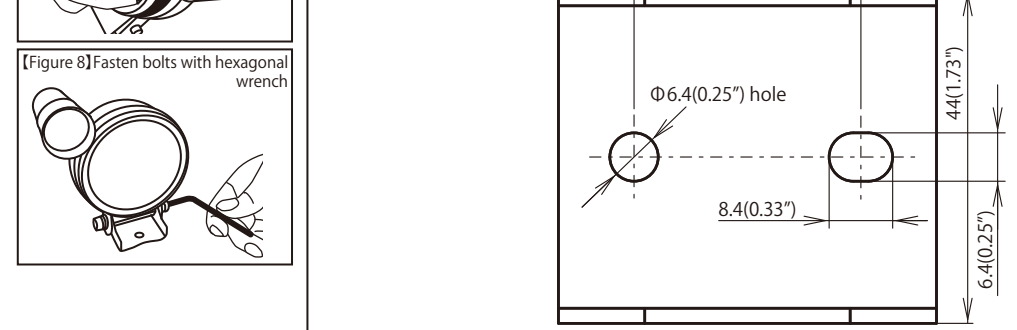
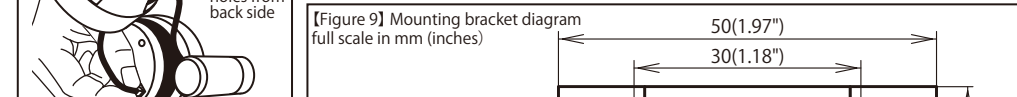
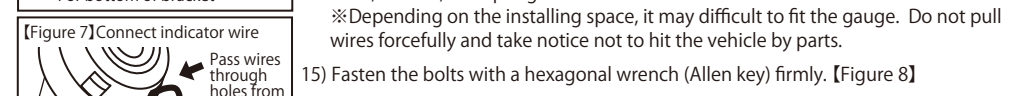
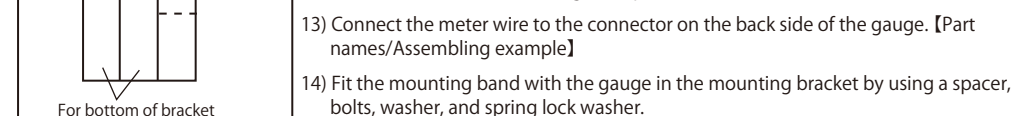

- Please refer to the Defi-Link ADVANCE Control unit operation manual for installation, operation, troubleshooting, repair parts, optional parts, and terms and conditions.
- The label stucked on the product is for the product traceability. Do not peel it off.