

# Manual

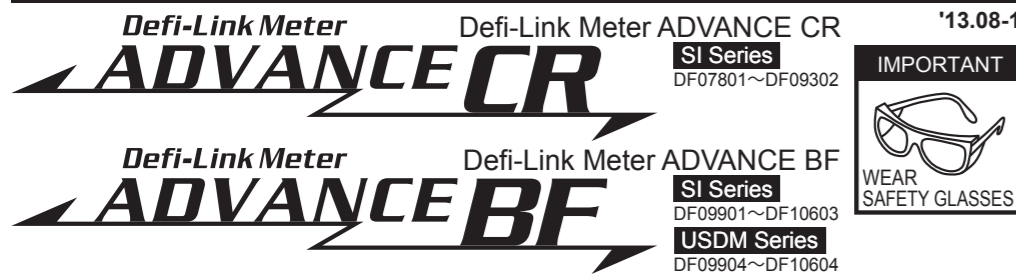

**This product functions with the Defi-Link ADVANCE Control unit. This product alone does not function. Please refer to the Defi-Link ADVANCE Control unit operation manual as well.**

Thank you very much for purchasing our product. This product is an additional product for providing information to automobile users about engine conditions and other important factors. Before installing and using the product, please read this manual and the warranty card thoroughly. All sections are for customers and installation personnel. After installation, please keep this manual and the warranty card for future reference. In the event that this product (or the vehicle in which it is installed) is lent to or transferred to another person, please be sure this operation manual and warranty card accompany the product.

Defi will not be held responsible for accidents or damages related to installation of this product. When installing and operating this product, be sure to read the cautionary items in the operation manual for the vehicle in which this product will be installed in addition to the manual of this product. Please obtain a full understanding of the cautionary items and use the product accordingly. Before using the product, please confirm all the components are included in the package.

<http://www.defi-shop.com/>

## Safety Warning [Please read carefully.]

In this manual, the degree of hazard arising from actions such as improper operation is separated into the 3 levels "Danger," "Warning," and "Caution." In addition, instructions that must be followed for safe and proper use of this product as well as practices that must be maintained are marked with a "Confirmation" heading. Please read and become familiar with these sections.

<b>Danger</b>	Indicates the imminent dangerous situation of death or serious injury if the product is mishandled.
<b>Warning</b>	Indicates the possibility of death or serious injury if the product is mishandled.
<b>Caution</b>	Indicates a conceivable source of personal injury or damage to equipment if the product is improperly operated.
<b>Confirmation</b>	Indicates an instruction that must be performed or practice that must be maintained.

### Properties for safety warning

	Indicates attention needs to be paid. (Including warnings)
	Indicates restricted actions. (PROHIBITED actions)
	Indicates actions that need to be carried out. (MUST actions)

### Before handling (for installation personnel)

- Danger**
  - Ensure that the vehicle will remain stationary and turn off the engine before installing this product. Failure to do so could result in a fire, and could make the vehicle move during installation.
  - Remove the key from the ignition and disconnect the negative (-) battery terminal prior to installation of this product. Failure to do so could result in a fire caused by an electrical short circuit.
  - Take care not to install this product in a way that interferes with safety equipment such as seat belts and air bag systems or vehicle operation equipment such as engine controls, steering wheel or brake systems. Interference with normal operation of the vehicle can result in an accident or fire.
  - Solder or use a solderless connector for wiring connections and make sure connections are insulated. In areas where there could be tension or sudden impacts on the wiring, safeguard the wiring with corrugated tubing or other shock absorbent material. Accidental shorts can cause fires.
  - When wiring power supply wire, to avoid the risk of electrical shock or fire, be sure to confirm that there is no disconnection or breakage of wire. Poor connection can result in short-circuit, electrical shock, fire, or other hazards.
  - The ignition-switched +12V(IGN) line must be connected to the vehicle's ignition-switched wire with a fuse of 30A or less. High-capacity fuse(more than 30A) will not blowout even with an abnormal current flow and may cause fire.
  - Discontinue use of this product if a blowout of the fuse has occurred. Continued use while the condition exists could result in an accident, fire, or damage to the vehicle.
  - Use the fuse of regulated capacity when the fuse of the power wire is changed. Using a fuse that exceeds regulated capacity may cause fire.
  - Do not install the product at the wet places. It may result in a fire caused by an electrical short circuit.

### Warning

- Carefully consider the installation location and driver's operation of the product before installation. Do not install the product where it interrupts driving and the safety devices of vehicle such as the airbag system. Be sure not to install the unit where it could fall. Improper installation or operation could cause the product to fall and damage the vehicle or cause serious danger by impeding driving.
- Do not disassemble or modify this product. Such actions will not only void the warranty but also damage or destroy the product.
- Do not perform installation of this product immediately after the engine has been switched off. The engine and exhaust system are extremely hot at this time and can cause burns if touched.
- Ensure that the wiring of this product does not have an adverse impact on the other wiring of the vehicle. Before tapping engine rev or speed signal from the ECU, please make sure that you have connected the power supply wire of the advance control unit. And then confirm that the DC Source LED of the advance control unit is lighted with ignition on. If it is functioning normally, remove negative terminal connector from battery and go ahead with wiring procedure. Incorrect wiring may destroy your ECU, ignition system and other engine management devices.
- Discontinue use of this product if the product doesn't operate or operates improperly. Continued use while the condition exists could result in an accident or fire.
- Please keep children and infants away from the installation area. Children may swallow small parts or be injured in other ways.
- Do not install this product in the area where safety equipment such as airbags are mounted. This may cause more injuries in the event of an accident.

### Caution

- This product is designed for use on 12V vehicles. Do not install this product on vehicles with 24V systems.
- Insulate any unused wires. If any wires or connectors loosen during installation, please make sure they are correctly reattached.
- Do not drop any of the components of this product. It may result in damage to the product.
- Do not apply excessive force on switches/terminals. It may result in damage to the product.
- Do not use wires other than the provided wires.
- Do not attach wires on the body of the vehicle or engine parts as this may result in damage to the product.
- Install wires away from ignition and also radio signal frequency interference as this could cause the gauges to malfunction.
- Please set it up so that the equipment such as the wireless machines and cellular phones that emits electric waves should not touch the advance control unit. It may result in incorrect operation.
- Do not place wires near the engine, exhaust pipe or turbine. It may result in damage or fusion of wires.
- Make sure the waterproof processing is done when diverging wires in the engine compartment.
- When installing the sensor, do not bend the wire near the sensor body.
- Wear gloves to avoid burns when soldering and cuts when installing wires, sharp edges of parts.
- Do not expose the advance control unit to moisture, dust or direct sunlight, or place product directly in front of heat vents.
- Install sensors away from hot or wet places.
- When using sunshade, put sunshade between products and windshield to avoid direct sun exposure.
- Use a dried soft cloth for cleanup. Do not use cleaners except neutral detergent. It may damage the product.
- Do not pull the wires out of connectors forcefully. The connectors may be broken and the wires may be cut. When pulling out the wires, press the lock firmly and unclip the locks of connectors.
- Do not install gauges into the passenger side or center of the dashboard. It doesn't meet vehicle safety standards.

### Confirmation

- Be sure to follow all instructions in this manual to ensure safe installation and operation of the product.
- When the negative (-) battery terminal is disconnected, equipment such as clocks and audio components having internal memory may lose their memory data. Follow the operation manual of each component to reset data after installation of this product.
- Do not lay the gauge face down due to oil leakage. Angle "A" must be more than 90 degrees.
- After installation is complete, return this operation manual, warranty card, and the package to the customer along with the warranty.
- The gauge pointer may not be in the proper position when you purchase the product. Normal function will resume when power is connected.
- Please confirm with the maintenance book on the car that the manufacturer issued when installing and detaching genuine parts.
- Before tapping wires, check the voltage of the existing wire. After tapping the wire, check the voltage of the tapped wire again to confirm whether you have tapped into the proper place.
- If car navigation system or car television is installed in vehicle, gauges and wires of this product need to be kept as far away as possible from the wiring and installing positions of car navigation system or car television. Failure to do so may result in interference of television display.
- On no event will Nippon Seiki Co., Ltd. be liable to you for any damages or losses of genuine parts for your vehicle while installing.

### About Installation and Operation(for customer and installation personnel)

#### Warning

- Please have this product installed by the retail store or dealer where it was purchased. Installation by the customer will void the warranty.
- Do not disassemble or modify this product. Such actions will not only void the warranty but also damage or destroy the product.
- In order to ensure safe driving, check the information on the gauge only for short periods of time. Looking at the display for long periods of time could distract adequate attention from the road and result in an accident.
- Discontinue use of this product if the gauge doesn't operate, water gets into the unit, or smoke or a strange odor comes from the unit. If such a condition occurs, contact the sales outlet or installation personnel as soon as possible. Continued use while the condition exists could result in an accident or fire.
- Do not operate during driving.
- Fix the switch unit and other parts tightly to the vehicle to avoid that children swallow those.

#### Caution

- On no event will Nippon Seiki Co., Ltd. be liable to you for any damages arising out of the use or inability to use the product, even if Nippon Seiki Co., Ltd. has been advised of the possibility of such damage.
- Do not pull the wires out of connectors forcefully. The connectors may be broken and the wires may be cut. When pulling out the wires, press the lock firmly and unclip the locks of connectors.

### Confirmation

- This product cannot be linked to the Defi-Link System.
- Do not connect more than one gauge of the same variety. (Ex. You can NOT connect 2 turbo gauges together.)
- The information displayed on this product are for reference purposes only. Please drive according to the indication of vehicle's originally equipped instruments.
- This product uses high luminance LEDs. When several gauges are lined up, there might be color difference in the LED production tolerance, but it is not malfunction.
- Please check the installed product regularly. Durability might deteriorate according to use conditions, etc.

## Common Features of ADVANCE CR and ADVANCE BF

- The advanced system (interactive communication) is implemented.
- Operation from distance is enabled using a remote control switch unit.
- Flat glass, high-definition scale and long, narrow pointer provides accurate indication and high visibility.
- The opening mode and ending mode can be selected from two variations.
- To install additional gauges, you can just make connection between gauges and attach the wire from the sensor to the advance control unit.
- Our original stepping motor is used to enable a smooth, instantaneous response to high performance sport driving.
- The microcontroller calibrates up to 270° of deflection angle in 3072 to 4600 segments (0.088° to 0.059°) and provides accurate vehicle information.
- Self-diagnosis function detects a disconnection of wire, short circuit and communication error, and indicates the error condition with the warning LED.
- A warning value (arbitrary) can be set. Buzzer sounds when the warning LED (red) is turned on (buzzer sound can be turned on/off).
- Data obtained during driving (peak value and warning value) can be stored up to three minutes, and the data can be replayed after driving.
- A dedicated mounting bracket and meter cup are provided as standard equipment.
- With both fuel pressure gauge and turbo installed, differential pressure can be displayed on the fuel pressure gauge.

### Features of ADVANCE CR

- The opening mode and ending mode can be selected from two variations designed for ADVANCE CR.
- The illumination at night can be switched between two different colors (white dial: amber red/blue, black dial: white/amber red).
- The outer edge of the glass is illuminated in red in a ring shape at night.
- A regular position bezel is included as standard equipment.

### Features of ADVANCE BF

- The opening mode and ending mode can be selected from two variations designed for ADVANCE BF.
- The light-emitting gauge always provides clear visibility with high contrast.
- Brightness can be adjusted by selecting from five levels for daytime and nighttime separately (nighttime dimming cancellation function is available).

## Product Specifications of ADVANCE CR and ADVANCE BF

- Power-supply voltage:** 10V to 16V DC (12V vehicles only)
- Current consumption:** the maximum value obtained when connecting seven gauges  
+B wire: 2A (IGN ON)  
5mA (IGN OFF)  
ILM wire: 800mA
- Temperature range (humidity is assumed to be 80% or lower) Unit: °C(°F)**

	Temperature range for storage	Temperature range for operation
CR/BF gauge	-30 (-22) ~ +80(176)	-20(-4) ~ +60(140)
ADVANCE Control unit	-30 (-22) ~ +80(176)	-20(-4) ~ +60(140)
Switch unit	-30 (-22) ~ +80(176)	-20(-4) ~ +60(140)
Boost sensor	-30 (-22) ~ +100(212)	-30 (-22) ~ +80(176)
Pressure sensor	-30 (-22) ~ +140(284)	-30 (-22) ~ +120(248)
Temperature sensor	-30 (-22) ~ +150(302)	-20 (-4) ~ +150(302)
Exhaust temperature sensor	-30 (-22) ~ +130(266)	-30 (-22) ~ +130(266)
- \*The upper temperature limit of sensor connectors is 105°C (221°F).
- \*The sensing part of exhaust temp. sensor is not included in the temperature range above.

<b>Illumination color</b>	Gauge pointer: red Warning LED: red PEAK LED: blue
<b>Illumination color at night for CR gauge</b>	White dial: amber red and blue Black dial: white and amber red Switchable between two different colors
<b>Illumination color for light-emitting BF gauge</b>	White/amber red/blue *The outer edge of the glass is not illuminated and the change of illumination color is not available on ADVANCE BF gauge.
<b>Dial</b>	Ring

\*How to operate ADVANCE BF: (Please refer to Def-Link ADVANCE Control unit operation manual for common operations of ADVANCE CR and ADVANCE BF.)

- Changing the opening/ending mode**  
For the opening mode and ending mode, you can select either A type (Simple) or B type (HA-NA-BI) by sliding the DIP switch 2 attached to the advance control unit. Before changing the opening/ending mode, make sure that the ignition is off. Please check both A type and B type operations for their performances.
- Real mode**  
Adjusting brightness manually  
You can adjust the brightness by pressing the right **◀ DIM/RESET** in the Real mode, Rec mode or Play mode. Five levels of brightness are provided for daytime and nighttime separately. Day mode is changed to night mode as illumination switch turns on. Also, an illumination cancellation function is available which enables to set the highest level of brightness for daytime in night mode. This can be done by pressing the right **◀ DIM/RESET** several times.
- Setting mode**  
Setting the warning value  
Regardless of the illumination status (ON/OFF), the dial illumination of selected gauge lights up with high brightness and the warning LED flashes, whereas the dial illumination of unselected gauge lights up with low brightness and the warning LED turns off.

Please refer to Def-link ADVANCE Control unit operation manual for common operations of ADVANCE CR and ADVANCE BF.

## Dimensions and part names

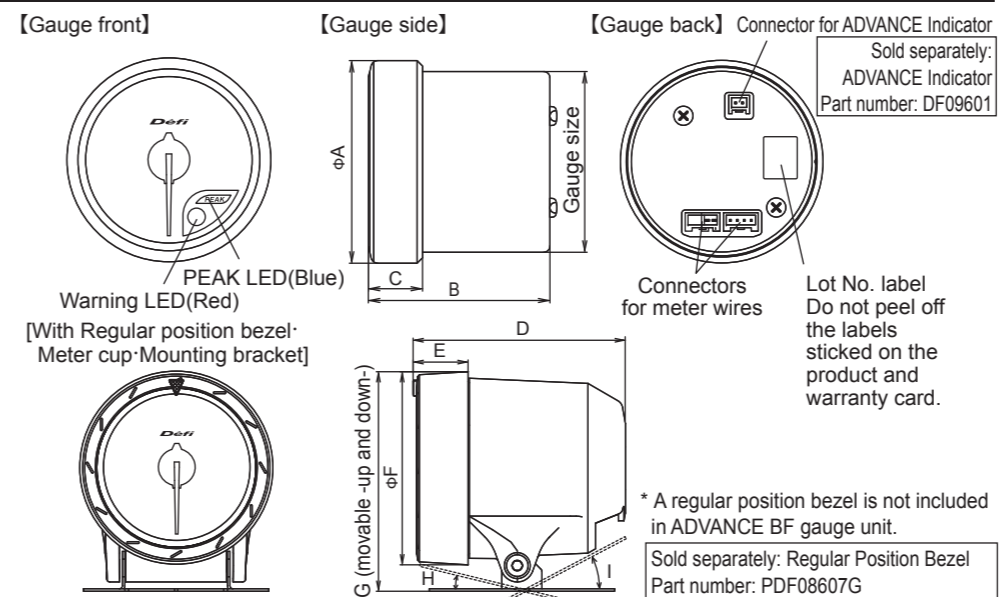

	Gauge size			Unit : mm(inches)
	CR Φ52(2 1/16")	CR Φ60(2 3/8")	BF Φ60(2 3/8")	
A	58.3(2.3")	66.3(2.3")	66.3(2.3")	
B	52.2(2.06")	52.2(2.06")	52.2(2.06")	
C	15.5(0.6")	15.5(0.6")	15.5(0.6")	
D	68.6(2.7")	68.6(2.7")	68.6(2.7")	
E	17.8(0.8")	17.8(0.8")	17.8(0.8")	
F	62.5(2.46")	70.5(2.77")	70.5(2.77")	
G	69.6(2.74") ~ 71.1(2.8")	77.6(3.05") ~ 79.1(3.1")	77.6(3.05") ~ 79.1(3.1")	
H	15"	15"	15"	
I	28"	32"	32"	

## Installation (for customer and installation personnel)

- Please refer to ADVANCE Control unit operation manual when installing gauges.
- Confirm all the components are included in the package.

### How to wire mete wires

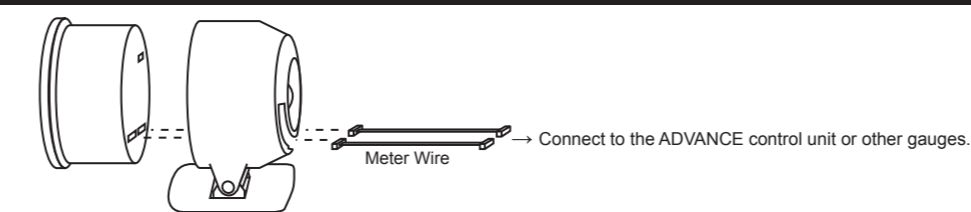

### How to use the regular position bezel

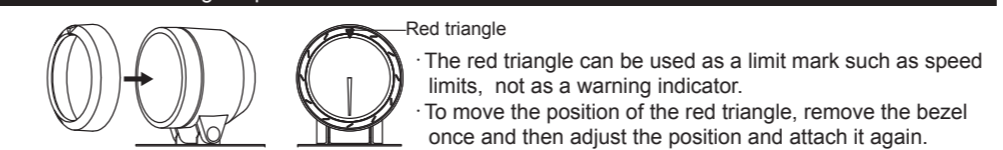

\*A regular position bezel is not included in ADVANCE BF gauge unit. (Sold separately: PDF08607G)

## How to attach Mounting bracket set

- Cut the double sided tape as shown in figure 1.
- Insert convex part of the mounting bracket over the legs of the meter cup. Attach the mounting bracket to the meter cup with the bolt, nut, and washer included in the kit as shown in figure 2.
- Attach one piece of double sided tape and the buffer on the gauge as shown in figure 3. (Cut the buffer into 16cm(6.3") when installing Φ52(2 1/16") series.)
- Pass the meter wires through the hole of the meter cup and connect them to the gauge.
- Place the gauge in the meter cup making sure that the wires are not sandwiched.
- Attach double sided tape on the back of the mounting bracket as shown in figure 4. Bend the mounting bracket to conform to the structure of the location where you intend to attach it.
- Fix the mounting bracket with commercial tapping screws as shown in figure 5.

- Use appropriate dashboard cleaning liquids (commercially available) to clean the area where the double sided tape will be attached.
- Do not lay the gauge face down due to oil leakage. Angle "A" must be more than 90 degrees.
- Use commercial tapping screws with double sided tapes to fix gauges on dashboard.

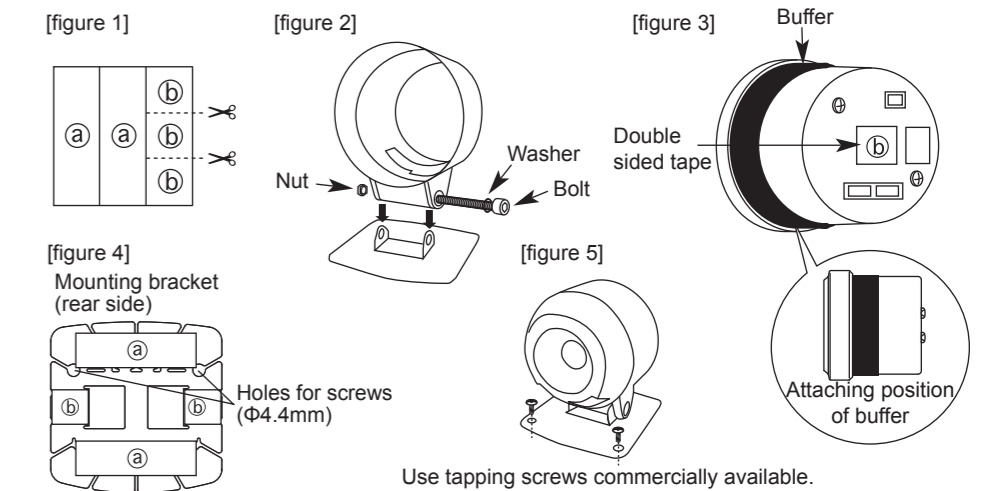

## Turbo/Boost/In-Mani (DF078, 079, 080, 086, 087, 088, 099, 100, 101 series)

### Components

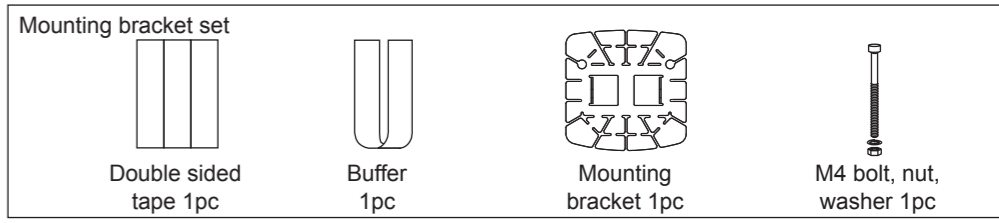
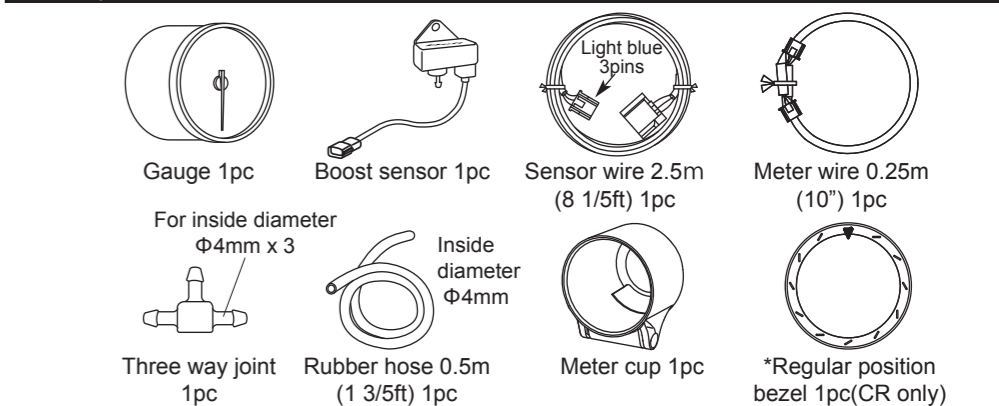

Operation manual (this sheet) and warranty card are included other than the parts listed above. Keep them at hand. \*A regular position bezel is not included in ADVANCE BF gauge unit. (Sold separately: PDF08607G)

### How to attach boost sensor

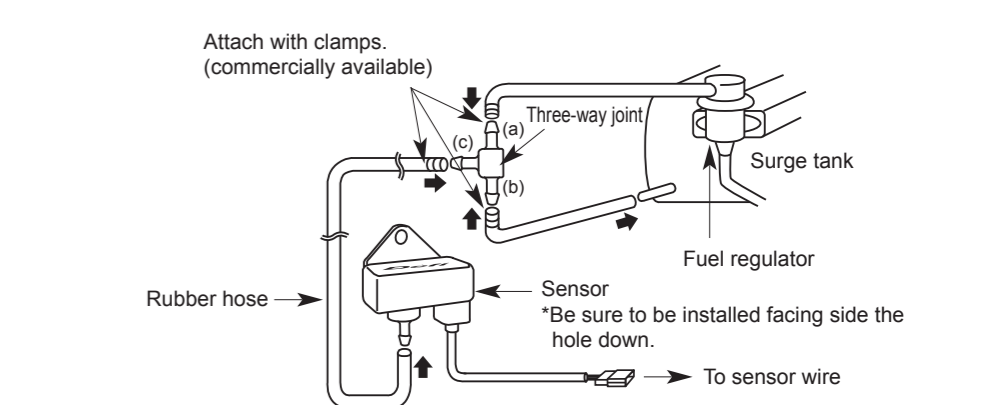

- The rubber hose attached to the sensor should be as short as possible. Attach the sensor with bolts (M6) in the engine compartment in an area where it will not be subject to excess heat or vibration.
- Access to the air pressure intake may be obtained between the surge tank and the fuel regulator.
  - Detach the vacuum hose from the surge tank side that has less pressure oscillations and connect it to the point (a) or (b) of the three way joint.
  - In order to connect the surge tank with three way joint, cut the required length of the hose from the included rubber hose.
  - Use the remaining rubber hose to connect the sensor to the three way joint.

- To avoid disconnection of rubber hose and air leak, attach hose clamps or use tie-wraps to secure the adjacent hose in the engine compartment. Disconnected hose or air leak could cause damage to the engine.

### Confirmation

- The length of the included rubber hose is 0.5m. Please adjust appropriately.
- The included three-way joint can be used only for the piping inner diameter of Φ4 between the surge tank and fuel pressure regulator. In case of other than Φ4, use another joint that fits properly.
- The sensor must be installed being the rubber hose connection side faced down.
- For vehicles which have a solenoid valve between the surge tank and the fuel pressure regulator, place a three-way joint closer to the surge tank side than to the solenoid side.

## OIL PRESS. (DF081, 089, 102 series)

### Components

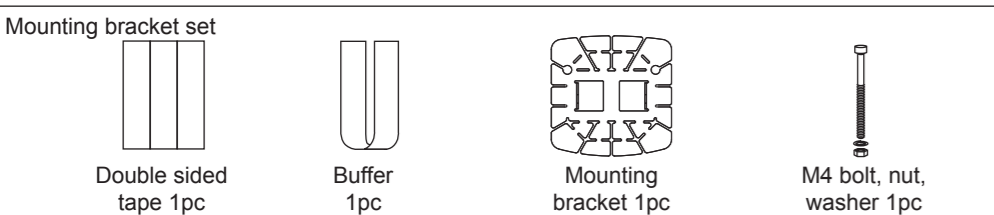
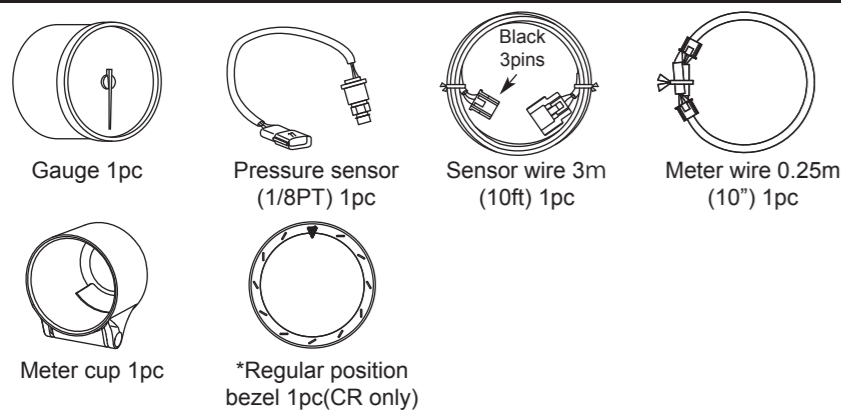

Operation manual (this sheet) and warranty card are included other than the parts listed above. Keep them at hand.  
\*A regular position bezel is not included in ADVANCE BF gauge unit. (Sold separately: PDF08607G)

### How to attach pressure sensor (Use a commercial sensor attachment.)

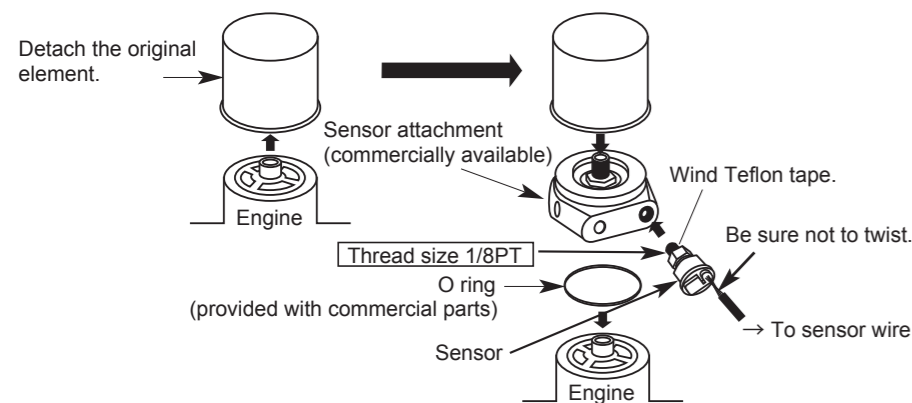

### Warning

- Be sure the sensor wire is not twisted when installing the sensor. The sensor wire will be cut.
- Oil spills by the installation work. Please replenish the engine with oil. The engine might overheat when oil is too little.
- To avoid oil leaks by installing of the sensors, use Teflon tape. Before driving, inspect oil blocks for leaks. Leaks could cause a fire or damage the engine.
- Do not install the sensor near oil pump. Do not install the sensor to pressure switch directly. Failure to do so could damage the sensor because the pressure pulsation is too big and exceed three times full-scale momentarily.
- To avoid the damage of the sensor wire, please fix the waterproof connector on the vehicle body and do not bend the sensor wire near the sensor.

### Confirmation

- The thread size of the pressure sensor is 1/8PT. Use a sensor attachment of 1/8PT.
- Tighten the sensor into the sensor attachment and then connect it to the sensor wire.

## FUEL PRESS. (DF082, 090, 103 series)

### Components

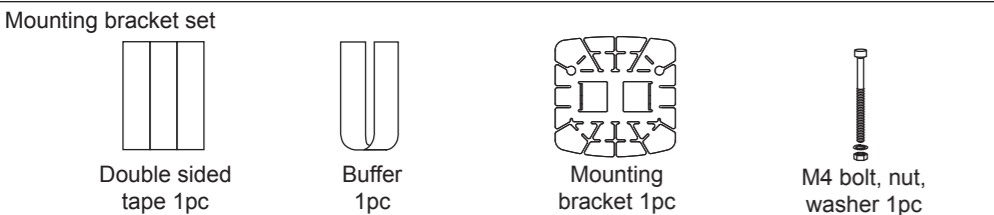
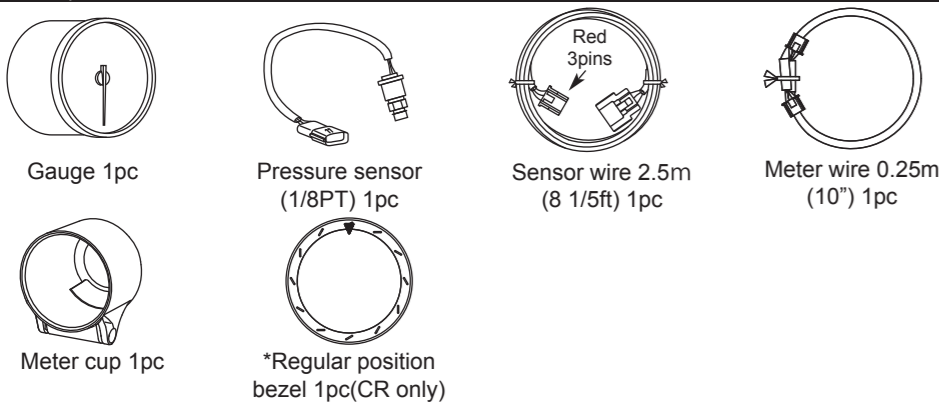

Operation manual (this sheet) and warranty card are included other than the parts listed above. Keep them at hand.  
\*A regular position bezel is not included in ADVANCE BF gauge unit. (Sold separately: PDF08607G)

### How to attach pressure sensor (Use a commercial three-way joint and hose unions.)

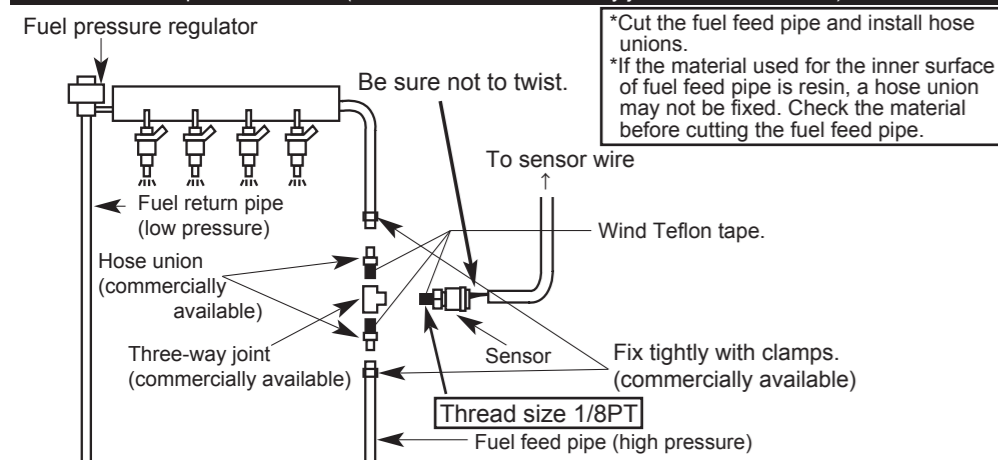

\*Cut the fuel feed pipe and install hose unions.  
\*If the material used for the inner surface of fuel feed pipe is resin, a hose union may not be fixed. Check the material before cutting the fuel feed pipe.

### Warning

- Be sure the sensor wire is not twisted when installing the sensor. The sensor wire will be cut.
- Before cutting the fuel feed pipe, be certain to remove the gas cap to relieve any pressure built up in the fuel tank.
- When cutting the fuel feed pipe, be certain to discharge static electricity. Otherwise, there is a possibility of the ignition in gasoline.
- Wear glasses to protect eyes when cutting the fuel filter pipe.
- To avoid fuel leaks during installation of the sensor, use Teflon tape. Attach hose connection and fuel feed tubing with clamps. Inspect pipes and hose connections for leaks before driving.
- To avoid the damage of the sensor wire, please fix the waterproof connector on the vehicle body and do not bend the sensor wire near the sensor.

### Confirmation

- The sensor must be installed on the feed (high pressure) pipe side between the fuel tank and the fuel pressure regulator.  
\*It is not possible to obtain accurate fuel pressure from the return (low pressure) side at the rear of the fuel pressure regulator.
- The thread size of hose unions and the three-way joint need to be 1/8PT. Use hose unions and a three-way joint of 1/8PT.
- Tighten the sensor into the sensor attachment and then connect it to the sensor wire.

## OIL TEMP. (DF083, 091, 104 series)

### Components

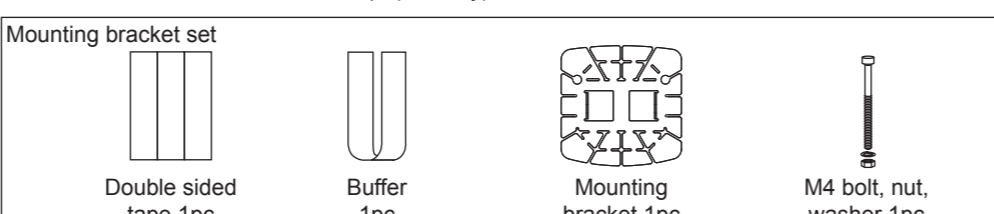
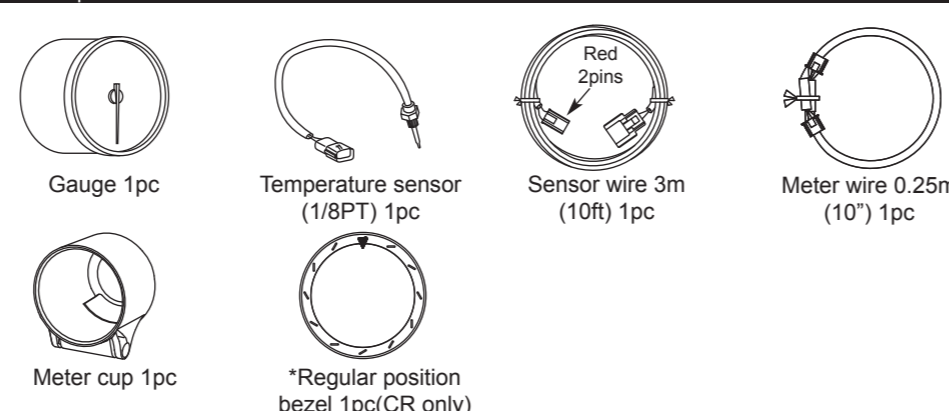

Operation manual (this sheet) and warranty card are included other than the parts listed above. Keep them at hand.  
\*A regular position bezel is not included in ADVANCE BF gauge unit. (Sold separately: PDF08607G)

### How to attach temperature sensor (Use a commercial sensor attachment.)

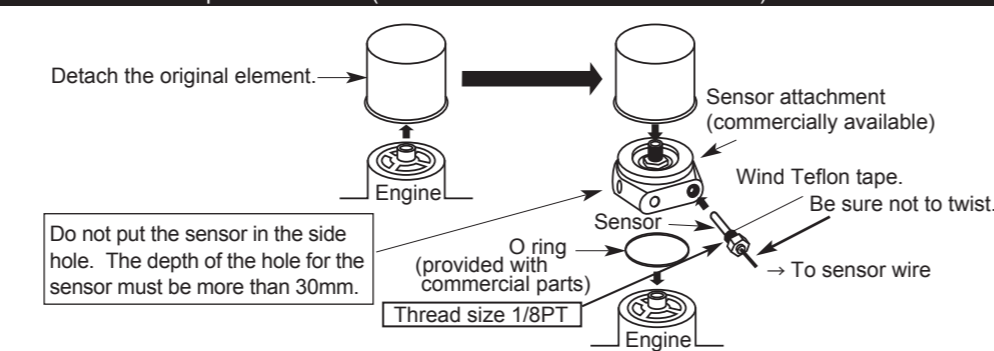

### Warning

- Be sure the sensor wire is not twisted when installing the sensor. The sensor wire will be cut.
- Oil spills by the installation work. Please replenish the engine with oil. The engine might overheat when oil is too little.
- To avoid oil leaks by installing of the sensors, use Teflon tape. Before driving, inspect oil blocks for leaks. Leaks could cause a fire or damage the engine.
- To avoid the damage of the sensor wire, please fix the waterproof connector on the vehicle body and do not bend the sensor wire near the sensor.

### Confirmation

- The thread size of the temperature sensor is 1/8PT. Use a sensor attachment of 1/8PT.
- The depth of the hole for the sensor must be more than 30mm.
- Tighten the sensor into the sensor attachment and then connect it to the sensor wire.

## WATER TEMP. (DF084, 092, 105 series)

### Components

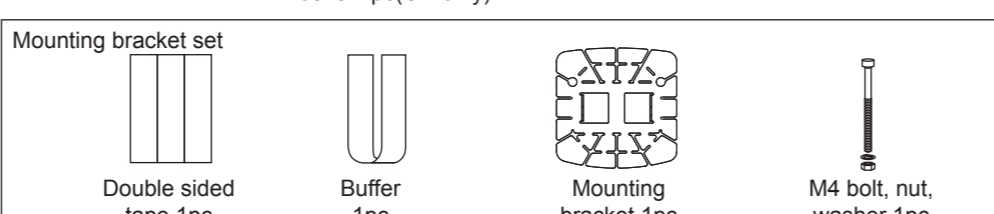
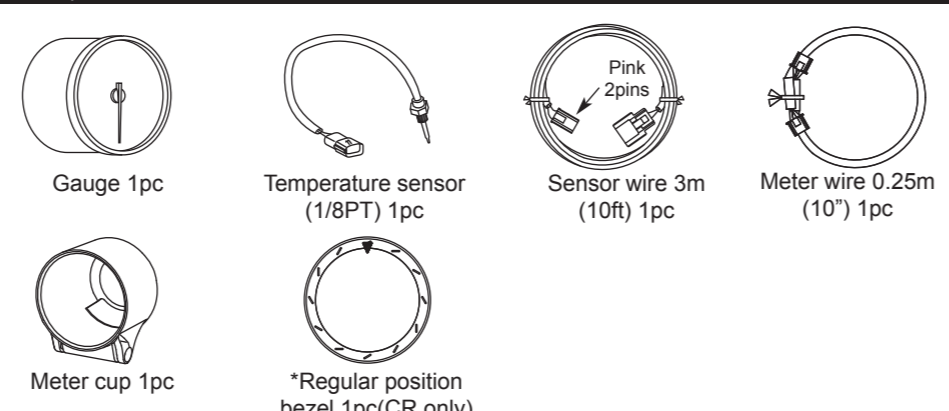

Operation manual (this sheet) and warranty card are included other than the parts listed above. Keep them at hand.  
\*A regular position bezel is not included in ADVANCE BF gauge unit. (Sold separately: PDF08607G)

### How to attach temperature sensor (Use a commercial sensor attachment.)

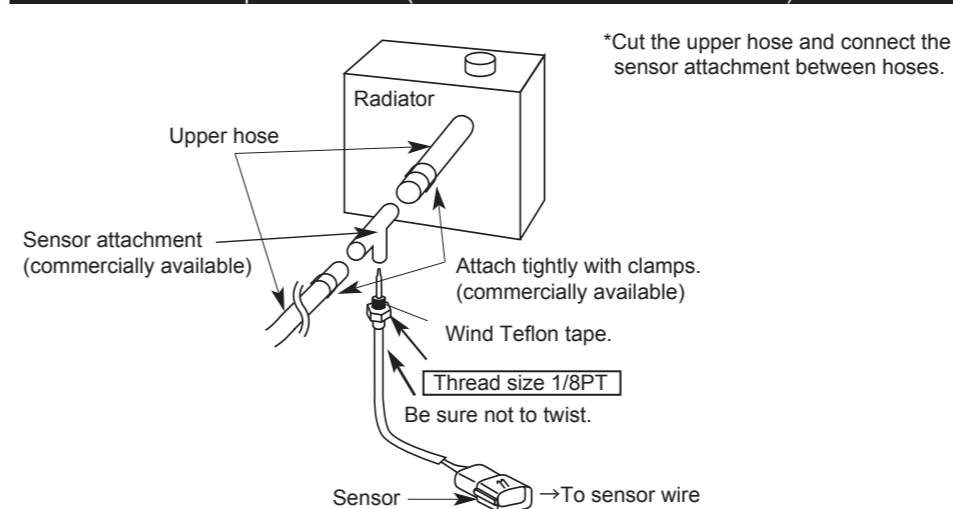

\*Cut the upper hose and connect the sensor attachment between hoses.

### Warning

- Be sure the sensor wire is not twisted when installing the sensor. The sensor wire will be cut.
- Coolant spills by the installation work. Please replenish the engine with coolant and bleed the air from the system, or the engine might overheat.
- To avoid water leaks during installation of the sensors, use Teflon tape. Attach the sensor attachment and upper hose with clamps. Inspect hose connections for leaks before driving.
- To avoid the damage of the sensor wire, please fix the waterproof connector on the vehicle body and do not bend the sensor wire near the sensor.

### Confirmation

- The thread size of the temperature sensor is 1/8PT. Use a sensor attachment of 1/8PT.
- Tighten the sensor into the sensor attachment and then connect it to the sensor wire.

## EXHAUST TEMP. (DF085, 093, 106 series)

### Components

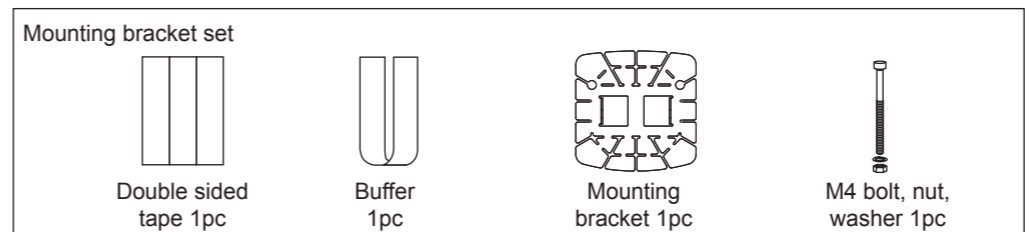
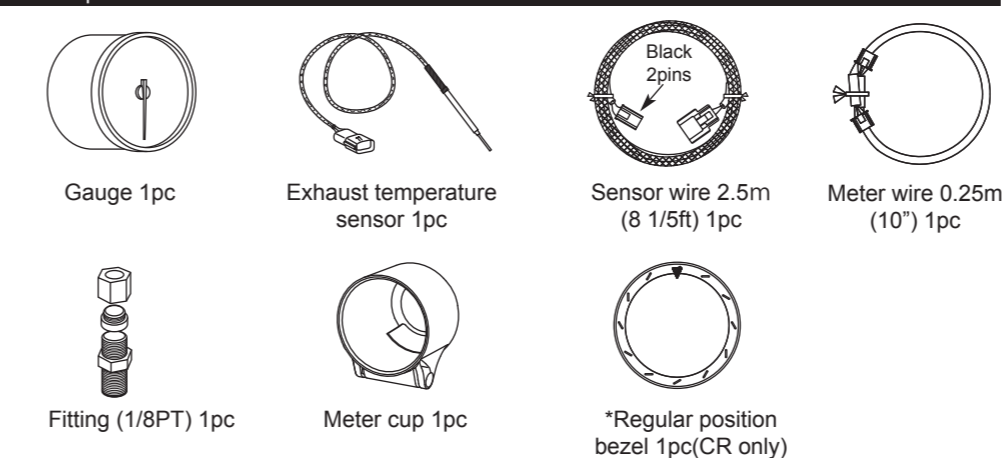

Operation manual (this sheet) and warranty card are included other than the parts listed above. Keep them at hand.  
\*A regular position bezel is not included in ADVANCE BF gauge unit. (Sold separately: PDF08607G)

### How to attach exhaust temperature sensor for exhaust temperature

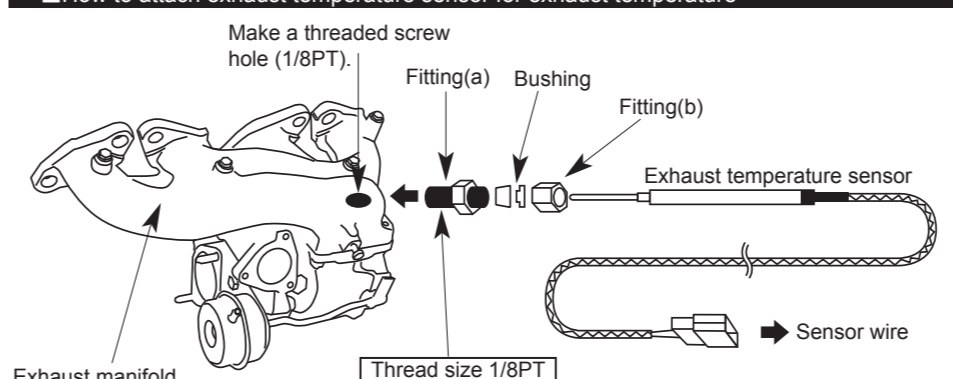

- Make a 1/8PT threaded screw hole in the exhaust manifold pipe. (Weld if the pipe wall thickness is not enough)
- Dismantle the fitting. Do not crush the bushing inside the fitting.
- Tighten the fitting(a) to the hole of the exhaust manifold.
- Pierce the sensor through the fitting(b) and the bushing.
- Insert the edge of the sensor into the fitting(a) and position it at the center of the exhaust pipe.
- Tighten the fitting(b).

### Warning

- To avoid personal injury, do not install the exhaust temperature sensor while the engine is hot.
- When making a hole, make sure no chip remains in the exhaust pipe or turbine. It may result in damage to the engine, exhaust pipe, or turbine.

### Confirmation

- The thread size of the fitting is 1/8PT. Make a threaded screw hole of 1/8PT.
- Tighten the sensor into the sensor attachment and then connect it to the sensor wire.

## Lineup (for customer)

Product Name	Product No.
Defi-Link ADVANCE Control unit	DF07703

Defi-Link Meter ADVANCE CR and ADVANCE BF need to be used with the advance control unit.  
One advance control unit can control up to 7 gauges.  
\*Do not connect more than one gauge of the same variety. (Ex. You can NOT connect 2 turbo gauges together.)  
\*In-Mani Press is an abbreviation of Intake Manifold Pressure.

### CR gauges (SI models)

Product name	Display range	Φ 52 series		Φ 60 series	
		White Dial	Black Dial	White Dial	Black Dial
Turbo2.0	-100~+200kPa	DF07801	DF07802	DF08601	DF08602
Turbo1.2	-100~+120kPa	DF07901	DF07902	DF08701	DF08702
In-Mani Press *	-100~+20kPa	DF08001	DF08002	DF08801	DF08802
Oil Press	0 ~ 1000kPa	DF08101	DF08102	DF08901	DF08902
Fuel Press	0 ~ 600kPa	DF08201	DF08202	DF09001	DF09002
Oil Temp	50 ~ 150°C	DF08301	DF08302	DF09101	DF09102
Water Temp	20 ~ 120°C	DF08401	DF08402	DF09201	DF09202
Exhaust Temp	200 ~ 1100°C	DF08501	DF08502	DF09301	DF09302
Tachometer	0 ~ 9000rpm			DF09403	DF09404

### BF gauges Φ 60 series (SI models)

Product name	Display range	White Model	Amber Red Model	Blue Model
Turbo2.0	-100~+200kPa	DF09901	DF09902	DF09903
Turbo1.2	-100~+120kPa	DF10001	DF10002	DF10003
In-Mani Press *	-100~+20kPa	DF10101	DF10102	DF10103
Oil Press	0 ~ 1000kPa	DF10201	DF10202	DF10203
Fuel Press	0 ~ 600kPa	DF10301	DF10302	DF10303
Oil Temp	50 ~ 150°C	DF10401	DF10402	DF10403
Water Temp	20 ~ 120°C	DF10501	DF10502	DF10503
Exhaust Temp	200 ~ 1100°C	DF10601	DF10602	DF10603
Tachometer	0 ~ 9000rpm	DF10704	DF10705	DF10706

### BF gauges Φ 2 3/8" series (USDM models)

Product name	Display range	Amber Red Model
Boost	-30inHg~+29PSI	DF09904
Oil Press	0 ~ 145PSI	DF10204
Fuel Press	0 ~ 87PSI	DF10304
Oil Temp	122 ~ 302 °F	DF10404
Water Temp	68 ~ 248 °F	DF10504
Exhaust Temp	392 ~ 2010 °F	DF10604

### Factory default settings of warning values

Gauge	Default setting	Unit	Setting range		Lighting condition
			Minimum	Maximum	
Turbo	100	kPa	-100	200	Set value and above
	14.5	PSI	-14.5	29	Set value and above
In-Mani Press	10	kPa	-100	200	Set value and above
	1.45	PSI	-14.5	29	Set value and above
Tachometer	7000	RPM	300	11000	Set value and above
	Oil press	120	kPa	0	1000
17.5		PSI	0	145	Set value and below
Fuel press	150	kPa	0	600	Set value and below
	21.8	PSI	0	87	Set value and below
Oil temp	125	°C	0	150	Set value and above
	257	°F	32	302	Set value and above
Water temp	105	°C	0	150	Set value and above
	221	°F	32	302	Set value and above
Exhaust temp	850	°C	0	1100	Set value and above
	1562	°F	32	2010	Set value and above

- Please refer to the Defi-Link ADVANCE Control unit operation manual for installation, operation, troubleshooting, repair parts, optional parts, and terms and conditions.

## Maintenance & Check/Warranty & Servicing

### Warranty card • Terms and conditions

This product is delivered with this operation manual and a warranty card. Please read terms and conditions in this manual thoroughly and keep the warranty card in a safe place. Failure to show this warranty will void the warranty.

### Warranty period

Limited one year warranty. The warranty period starts at the date of retail purchase by the original end-user purchase. Please confirm the warranty card is provided with the information of retail store where purchased. Please refer to Limited Warranty for details.

△ Except in the case of defects, we shall not be liable for any trouble including violation, accident or improper wiring resulting from using this product.

○ The warranty does not cover any unauthorized repair performed or caused to be performed by the end user. Such action can destroy or damage this product.

### Inspection

Please ask the shop you purchased the product for inspection if any defect in product is suspected. We don't accept the order of fixing because Defi products require installation and wiring to the vehicle. In case you cannot go to the shop you purchased because of move-out or closure of shop, please ask the nearest Defi Distributor listed in the Defi website.

- For a repair/inspection service, take the warranty card and customer contact information with you.

Please conduct periodic inspections by Defi through a shop which sells Defi products or Defi's official distributor every five years. Inspection is available at an additional cost. In the case you purchase used products or used vehicles with products of Defi, please have an inspection by Defi as well before using them.

### Label

The label stucked on the product is for the product traceability. Do not peel it off.

### Repairing

When a repair is necessary, we will return the inspection result report through the store to you. After receiving a repair service request, we start repairing. Ask the store how much it costs and how long it takes to repair.

### Discarding the products

Please dispose products in accordance with disposal laws, state laws and local government. A recycle label on the package indicates that the package is recyclable.

### Defi-Link Meter ADVANCE CR & ADVANCE BF Operation Manual

Issue First edition: August, 2013

Manufacturer Nippon Seiki Co., Ltd.

Contact Information Defi, Nippon Seiki Co., Ltd.

[Address] 190-1 Fujishashi 1-chome, Nagaoka-shi, Niigata 940-2141 JAPAN

[URL] <http://www.defi-shop.com/>

PAT. 3019067 PAT. 3019939

**NIPPON SEIKI CO., LTD.**